

The Physics of the Human Body

Companion Manual
Physics 3110

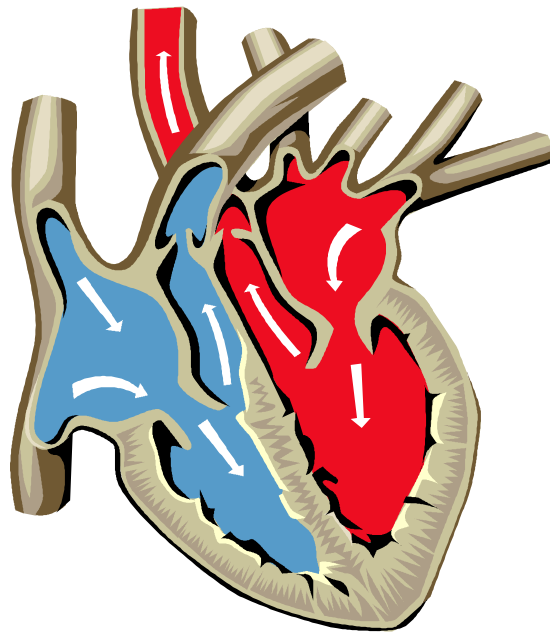

CARDIAC CYCLE

Richard J. Ingebretsen, M.D., Ph.D.

INDEX

Chapter 3: Muscles and Forces	3
The Rotator Cuff and Shoulder Impingement Syndrome, Michael Doleac ..	4
Physics of Arm Wrestling	5
High Velocity Injuries, Harland Hayes, University of Utah School of Medicine	7
Chapter 4: Physics of the Skeleton	18
Origin of Stress Generated Potential in Bones	19
Chapter 5: Pressure in the Body	22
Chapter 7: Physics of the Lungs and Breathing.	25
Chapter 8: Physics of the Cardiovasculature System.	29
Chapter 11: Physics of the Ear and Hearing.	36
Cochlear Implants.	37
Chapter 13: Medical Imaging and the Treatment of Cancer.	40
X-Rays.	41
Using X-Rays.	44
Gamma Rays.	47
Particle Accelerators.	49
Magnetic Resonance Imagine (MRI)	50
Brachytherapy	54
Radiation Injury.	55
Problems	
Chapter 2: Energy, Heat, Work and Power of the Human Body.	62
Chapter 3: Muscles and Forces.	63
Chapter 4: Physics of the Skeleton.	65
Chapter 5: Pressure in the Body.	66
Chapter 7: Physics of the Skeleton.	67
Chapter 8: Physics of the Cardio vasculature System.	68
Chapter 9: Electrical Signals within the Body.	69
Chapter 11: Physics of the Ear and Hearing.	70
Chapter 12: Physics of the Eye and Vision.	71
Chapter 13: Physics of Medical Imaging	72

Chapter 3: Muscles and Forces

Rotator Cuff and Shoulder Impingement Syndrome

Michael Doleac

The rotator cuff is a very important part of the functional anatomy of the shoulder. It consists of four muscles: the supraspinatus, the infraspinatus, the teres minor, and the subscapularis. This group serves as abductors, lateral rotators, and medial rotators of the shoulder, but they also have another very important function. They act as depressors of the humerus. This function keeps the action of the deltoid from pulling the head of the humerus upward into the subacromial space, which would cause impingement of the cuff. When this happens, the shoulder impingement syndrome that results can turn into a self-promoting cycle.

Impingement is caused when the subacromial space, the area between the top of the humerus and the bottom of the acromion, becomes closed off and pinches the rotator cuff. Symptoms include pain, weakness, and loss of motion. Movements above the shoulder tend to increase pain, and pain while sleeping is often encountered. Besides weakness of the rotator cuff, impingement can be caused by abnormal acromions, acromioclavicular joint arthritis, and a calcified coracoacromial ligament. When impingement occurs, the natural response of the body is to the pain is the disuse of the muscles. This disuse causes the muscles and tendons to weaken, leaving the action of the deltoid even more unopposed, and therefore reinforcing the cycle.

Impingement syndrome may be classified in three stages. Stage one is usually associated with an overuse injury by someone who is under the age of 25. The rotator cuff is weakened, but the condition is often reversible. Stage two usually involves people from the ages of 25 to 40, and the condition is more advanced, with some irreversible tendon damage beginning to arise. Stage three is the result of years of build up, and often involves tendon rupture or tear. This is seen mostly in patients over the age of 50.

Understanding the impingement syndrome is aided by understanding the physical properties of the tendons, which make up the cuff. The strength and stiffness of tendons, which give them their mechanical advantages, comes from collagen molecules. Collagen molecules run parallel to each other and derive their characteristic strength from the cross-linkage between them. New collagen has relatively few cross-links, but as it matures, the number of cross-links grows, therefore increasing the strength and stiffness of the fiber. This maturation process begins to level off with age however. In older patients, the number of stable cross-links being formed between collagen molecules drops off considerably, therefore reducing the strength of the tendon. Tendon strength is also affected by the demand placed on it. An active person who exercises frequently will have much stronger tendons than an inactive person will. Disuse or immobilization of tendons causes them to weaken considerably, as no demands are being placed on them.

Impingement in a young patient is often reversible because of the properties of the tendons. Treatment is rather conservative, consisting of rest and ice, followed by a strengthening program and possibly some physical therapy. A sling is never used because immobilization of the joint would just weaken the rotator cuff and add to the problem. The strengthening program will lead to the development of more stable cross-links between the collagen fibers, increasing the overall stability of the tendons and the entire rotator cuff. The more stable rotator cuff will relieve the impingement by holding the humerus in its proper position.

Physics of Arm Wrestling

Of the muscles in the human body, there are three kinds, smooth, striated, and cardiac. When talking about mechanical advantage in muscles the focus turns primarily to striated muscle. Striated muscles are the voluntary work force behind all major body movements and include; triceps, biceps, pectoral etc.

Under stress striated muscle can react in different ways according to conditioning. In a drop-jump study of trained and untrained subjects it was revealed that a trained gastrocnemius muscle contracts and relaxes at a faster and more efficient rate. In the untrained subject the muscle appeared to tense up and not have as high a contraction strength. Muscle contraction in striated muscle tissue can contract up to 15-20 percent of its resting length. This is largely due to the electric force of attraction. When examined under an electron microscope the muscles reveal smaller bundles called myofibrils, which break up into smaller parts called filaments. These filaments consist of the proteins myosin (thick), and actin (thin). It is at the microscopic level that the contraction begins. The filament parts slide together and collapse on themselves and by working together can lift an arm with a load.

Although it is well accepted that muscle contractions occur as a result of electrochemical interactions the contraction mechanism at this level is not completely understood, however, attractive electrical forces must be involved, for they are the only known force available. Even though electrical forces can also be repulsive, no muscles are able to push all they can do is pull. To compensate for the muscle's ability to pull in only one direction the body is constructed with opposing muscle groups that allow the limb to be moved back the opposing direction.

The mechanical advantage of a muscle and joint can be calculated. The elbow, a third class lever is a good demonstration of mechanical work. The elbow as a fulcrum is near the upward pulling force of the biceps, this distance is 7.5 times shorter than the weight-bearing extremity. To calculate the work produced by the biceps would involve determining the weight of the arm and the weight of the load in the hand.

$$M = 3.5 H + 7.5 W \text{ (for a 30 N load and a 14 N arm weight).}$$

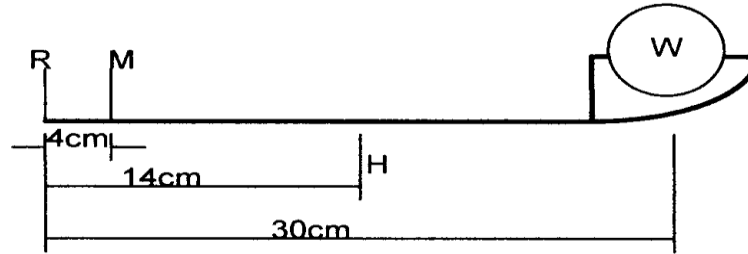

R is the fulcrum, M is the biceps muscle, W is the load on the hand and H is the combined weight of the tissue and bones of the arm.

When considering arm wrestling more than just the biceps muscles are involved (aside from the psychological factors). Including all the factors of arm wrestling into the equation is complicated, but it can be discussed rather simply. One factor the deltoid should be figured into the calculations to find the most probable outcome. When one of the arms is extended (i.e., the one who is losing) the biceps is the major source of resistance. In fact when someone is defeated it is mainly because of biceps failure, which fails because of overextension. Likewise when the same person is beyond 90 degrees in their favor the biceps no longer has effect because it has flexed to its limit of effectiveness. This is where the deltoid takes over and pushes the biceps of the opponent's arm the rest of the 180 degrees. Because the elbow only bends in one direction the effectiveness of the deltoid is derived straight across to the load of the opponent's hand. The effectiveness of the deltoid is greatest when the hand is closest to the deltoid.

This is why it is easier to move past the mid 90 degree point in arm wrestling and always hardest at the last few inches, as in this case with the deltoid at the last 178 degrees the hand is furthest away from the shoulder. This is one of the reasons that people have the habit of putting their head down near their hand when they are at the last part of the match, weather winning or losing. The final factor in arm wrestling is the fatigue factor from lactic acid. It is the deciding factor in most well-matched opponents.

A good summation of the effectiveness of the deltoid is given as:

$$T = (2W_1 + 4W_2) / \sin x$$

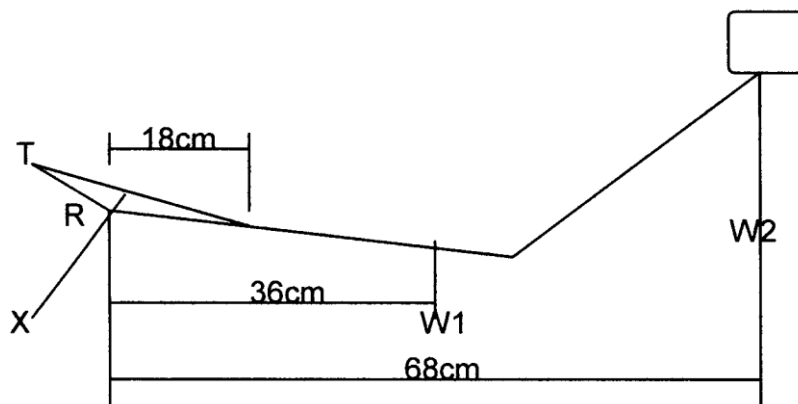

HIGH-VELOCITY INJURIES

Harland Hayes, University of Utah School of Medicine

It should be no great surprise to find out that the most serious of injuries that occur in the back country are those that are associated when people are moving with speed. There are common sports that by their very nature require speed such as skiing where injuries don't have to occur. However, there are other sports that demand deliberate even delicate moves, such as rock climbing, where speed gained from a fall could be deadly. In any event, people just don't experience major trauma unless high velocity is involved. Three of the most common outdoor activities where injuries from high velocity occur are mountain biking, skiing and rock climbing.

Mountain Bike Injuries

The National Bicycle Institute of America reports that there are 52 million cyclists in America today. Bicycling is one of the fastest growing recreational and competitive activities in the U.S. As this sport increases in popularity, bicycling related injuries will become increasingly more common. Many in the backcountry away from traditional help

CYCLING ASSOCIATED TRAUMA

Injury types in general cycling accidents

Contusions	39.2%
Abrasions	36.1%
Lacerations	23.2%
Fractures	16.1%

Injuries by type for males

Wound	36.5%
Bruise	21.6%
Strain	16.3%
Tendinitis	10.1%
Sprain	8.2%
Fracture	4.3%
Dislocation	2.9%

Injuries by type for females

Wound	35.2%
Bruise	33.0%
Strain	15.4%
Sprain	6.6%
Tendinitis	5.5%
Fracture	4.4%

Percent injury by anatomical site and number receiving medical treatment, categorized by gender

	<u>MALE</u>	<u>FEMALE</u>		<u>MALE</u>	<u>FEMALE</u>
Neck	44.2%	54.9%	Thighs	7.5%	9.8%
Knees	40.1%	43.7%	Elbows	4.1%	5.8%
Groin/Buttocks	37.4%	33.9%	Head	4.1%	5.3%
Hands	29.6%	33.0%	Hips	4.8%	3.6%
Shoulders	24.8%	37.5%	Ankles	3.7%	3.6%
Back	31.6%	28.6%	Achilles	2.0%	5.8%
Feet	13.9%	16.5%			

ABRASIONS

Abrasions are rarely life threatening but are a significant source of morbidity in mountain biking. Abrasions most typically occur on the face, hands, legs, and shoulders after a biking fall. Abrasions most typically occur on the face, head, and extensor surfaces.

Underlying Trauma

When abrasions are present, first, rule out more significant underlying trauma. Look for the following:

- Fractures
- Vascular injury
- Neurologic damage

Clean and debride the wound

Treat mountain biking wounds as outlined in the wound management section, taking the following into consideration:

- Soaps and peroxides effectively remove oils, tars and blood.
- Ionophores, povidone works especially well, are used to clean and sterilize the wound.
- In order to prevent tattooing and infection, carefully remove all foreign bodies.
- If medical supplies are not available, rinse the wound with your water bottle. Compress and elevate until hemostasis is attained.
- Apply a sterile non-adhesive dressing.
- Silver sulfadiazine (Silvadene) or Polymyxin B with Bacitracin may be applied for pain relief and anti-bacterial effect.
- Hydrocolloid dressing increases comfort and aids in healing.

FRACTURES

Treat mountain biking fractures as outlined in the musculoskeletal injury section. Common fractures associated with mountain biking include:

Distal radial fracture (Colle's fracture)

- Diagnose radiographically
- Treat with closed reduction maintenance in a carefully molded cast. Check every two weeks to prevent misalignment.
- Stabilize the radius in supination and limit extension for transport.

Clavicle fracture

Clavicle fractures occur most commonly in the middle third portion of the clavicle.

- Treat with a figure of eight sling.
 - Use a triangle bandage.
 - A temporary sling may be fashioned using a bicycle inner tube if no bandages are available.

Scaphoid fractures

Scaphoid fractures are the most common fracture which occurs in the hand.

- 12.5% of the time there is no radiographic evidence of a fracture; therefore, it is important to carefully look for clinical signs of pathology.
 - If there is pain in the anatomical snuffbox, suspect a scaphoid fracture and treat accordingly, external fixation with a forearm/hand cast for 4-5 weeks.

Hamate fractures

A hamate fracture should be suspected if persistent ulnar neuropathy is evident. The diagnosis can only be confirmed by CT or bone scan. Treatment is surgical.

SHOULDER DISLOCATION

Although anterior dislocation is typically more common, posterior dislocations are more common in mountain biking. Serious vascular and/or neurologic injury frequently occurs in association with posterior dislocation. Expedient follow-up is advised.

Diagnosis

The joint is exquisitely tender. A visible step off and guarding may be present. A limited range of motion is typically present.

- Assess radial and ulnar pulses.
- Assess motor and sensory innervation.

Reduction

Generally, posterior and first time anterior dislocations are not reduced on site. Use the following guidelines if reduction is deemed appropriate:

ANTERIOR REDUCTION

- With the patient supine, put his arm in slight abduction and forward flexion, apply traction and gently internally rotate.
- Place the patient in a prone position on a table with his arm hanging over the side. Apply traction by suspending five to ten pounds from the affected limb.

POSTERIOR REDUCTION

Note-Most posterior dislocations reduce spontaneously.

- Gently internally rotate the patient's arm.
- Apply longitudinal traction and place posterior pressure on the humeral head.
- Gently rotate externally while lifting the humeral head back into the glenoid fossa.

*Immobilization and transport are indicated if there is questionable vascular or neurological damage.

HEAD INJURY AND CONCUSSION

There are around 300 bicycle injuries in the United States each year. With the high speeds, technical terrain, and proximity of the riders often present in cycling events, accidents and head injury are not uncommon. Data shows that there is a 50-50 chance of obtaining a head injury in any accident. Close observation and assessment of injured riders is critical in preventing catastrophic brain injury. **WEAR A HELMET!** There is a 75% reduction in risk if a rider wears a helmet.

Concussion is a trauma-induced change in mental status. It is not necessarily associated with a loss of consciousness.

- Confusion and amnesia are hallmarks
- Disturbance of vigilance with heightened distractibility.
- Inability to maintain a coherent stream of thought.
- Inability to carry out a sequence of goal oriented tasks.

Common Features and Symptoms of Concussion

FEATURES

- Vacant stare (befuddled facial expression)
- Delayed verbal and motor responses (slow to answer questions or follow instructions)
- Confusion and inability to focus attention (easily distracted and unable to follow through with normal activities)
- Disorientation (walking in the wrong direction, unaware of time, date, and place)
- Slurred or incoherent speech (making disjointed or incomprehensible statements)
- Gross observable incoordination (stumbling, inability to walk tandem/straight line)
- Emotions out of proportion to circumstances (distraught, crying for no apparent reason)
- Memory deficits (exhibited by the athlete repeatedly asking the same question that has already been answered, or inability to memorize and recall 3 of 3 words or 3 of 3 objects in 5 minutes)
- Any period of loss of consciousness (paralytic coma, unresponsiveness to arousal)

SYMPTOMS

Early (minutes and hours):

- Headache
- Dizziness or vertigo
- Lack of awareness of surroundings
- Nausea or vomiting

Late (days to weeks):

- Persistent low grade headache
- Light-headedness
- Poor attention and concentration
- Memory dysfunction
- Easy fatigability
- Irritability and low frustration tolerance
- Intolerance of bright lights or difficulty focusing vision
- Intolerance of loud noises, sometimes ringing in the ears
- Anxiety and/or depressed mood
- Sleep disturbance

MENTAL STATUS TESTING

Orientation

Time, place, person, and situation (circumstances of injury)

Concentration

Digits backward

Months of the year in reverse order

Memory

Recall of three words and three objects at 0 and 5 minutes

Recent newsworthy events

NEUROLOGIC EXAMINATION

- Strength
- Sensation
- Coordination and agility

*Any appearance of associated symptoms is abnormal, e.g., headache, dizziness, nausea, unsteadiness, photophobia, blurred or double vision, emotional lability, or mental status changes.

TREATMENT

Symptoms lasting longer than 15 minutes warrant medical observation. If headaches or neurologic symptoms worsen, or if a loss of consciousness occurred, expeditious extrication of the patient is in order for urgent neurosurgical consult.

Prevention and Overuse Injuries

In order to treat and prevent many common injuries and complaints, it is necessary for the physician to understand not only the anatomical and physiological aspects of cycling, but also the interface between cyclist and bicycle. Proper bicycle set up is integral in avoiding common overuse syndromes. In a study of 294 male and 224 female randomly selected cyclists 85% complained of overuse syndromes. The most common complaints were pain in the following: neck and back (48.8 %), knee (41.7 %), groin and buttock (36.1%), hand (31.1%).

NECK AND BACK PAIN**Etiology**

- Most commonly results from poor positioning of the rider on the bicycle.
- A micro-whiplash syndrome results from trail and road vibration.

Acute management

- Correct bicycle set up.
- Massage, ice, and stretching
- Acetaminophen, NSAIDS, or other non-sedating pain relievers.
- Pulsed alternating electrical stimulation
- Injection of equal parts 1% lidocaine and 0.25% bupivacaine confers immediate relief.

KNEE PAIN/TENDONITIS**PATELLAR**

- Often presents with pain, swelling, and point tenderness.
- Exacerbated by saddle position that is too low or too far left.

Treatment

- RICE therapy (Rest, Ice, Compression, Elevation)
- Correct bike setup
- Rest- (no hills or big gears)

ILIO-TIBIAL BAND SYNDROME

- Aggravated by excessive internal, rotation of cleats, or a saddle that is too high and posterior.

Treatment

- RICE therapy
- Correct bike setup
- Rest and stretching

Note- NSAIDS have been shown to increase the rate of recovery in some people, allowing quicker return to activity; however, with potential side effects of nausea, dyspepsia, and ulcer their use is controversial.

SADDLE ASSOCIATED SYMPTOMS**Saddle Sores**

- Chafing - local skin irritation
- Keep area clean and dry.
- Use seamless shorts.
- Non fluorinated steroid creams.

Compression injury

- Pudendal nerve compression leading to numbness of scrotum and penile shaft.
 - Change position of saddle.
 - Stand intermittently and change positions while riding.
 - Change saddle.

Urethritis/Prostatitis

Infections can occur that are secondary to inflammation.

HAND

The ulnar nerve is a relatively superficial structure as it enters the hand via the ulnar tunnel. It is for this reason that compression injury often occurs. Ulnar injury may be associated with motor loss, sensory loss, or both motor and sensory loss.

- Virtually everyone recovers with rest in 3 - 6 months.
- Correct bike setup.
- Change positions frequently while riding.

Trauma to the Hand

Because of the nature of mountain biking falls, injuries to the hand occur very frequently. Be prepared to treat abrasions, fractures, and contusions to the hand. Always wear padded biking gloves when riding.

SADDLE HEIGHT & POSITIONING

Conditions which might arise if saddle is too high:

- Biceps tendonitis
- Saddle related syndromes
- pudendal neuropathy/impotence
- chafing to skin ulcerations

Conditions which might arise if saddle is too low:

- Patellar tendonitis
- Quadriceps tendonitis

ADJUSTING YOUR SEAT

Determine proper seat height by sitting on the seat and straightening one leg so that your heel is on the pedal. This is the correct seat height for most cross-country situations once you place the widest part of your foot on the pedal. Adjust seat height as necessary for varying terrain. For males, seat angle should be level to slightly elevated. For females, level to slightly depressed.

HANDLEBAR POSITIONING

Remember the following bar positioning tips before starting a long ride:

- Bars should be 1 to 4 inches below the saddle with the distance below the saddle proportional to the rider's height.
- A plumbline dropped from the rider's nose should bisect the handlebar.
- One to three inches between the elbow and the knee with the arm at 65 - 70 degrees of flexion.
- Approximately one third of the body weight should be resting on the arms.
- Raising the bar height and shortening extension can treat neck and back pain.

Skiing Injuries

INTRODUCTION

Skiing and snowboarding continue to rise in popularity throughout the world. Skiers and snowboarders can often reach very fast speeds while on busy ski slopes or skiing through the trees. In general, ski injuries are the result of falls, collisions or overuse injuries. Loose, heavy snow increases the risk of lower extremity injuries as skis can get trapped in the snow and lead to knee and ankle injuries. Icy conditions may cause skis to slide out from under the skier, increasing the rate of upper extremity injuries. Skiing on an unstable snowcap or an overhanging cornice can trigger an avalanche which may result in serious trauma and death of multiple skiers. Along with the rise in popularity of these winter sports comes the need for medical professionals who can diagnose, stabilize, and transport injured skiers in the mountains.

STATISTICS

Injury Statistics

- Since the 1970's, the overall rate of ski injuries has decreased by about 50%. It now stands at between 2-4 injuries per thousand skier days. The decrease in injury rate is directly related to developments in ski equipment. The biggest decrease has been in lower limb fractures due to the introduction of release binding systems and plastic-shelled alpine boots. Rates of shoulder, thumb and head injuries have not changed much. The most alarming fact is that the rate of serious knee injuries (in particular ACL tears) has gone up 240%. This, too, may be due to plastic-shelled alpine boots coupled with current binding systems that have not been able to prevent this type of injury. Many manufacturers are doing research on methods to allow the binding to release during ACL-injury-inducing falls while preventing premature release of the binding under normal skiing activity.

Fatality Statistics

- Fatalities are even rarer, about 0.75 per one million skier days. Deaths can be divided into those due to medical conditions (heart attacks, asthma etc) and those related to trauma. Traumatic deaths usually occur as a consequence of an avalanche or as a result of a high-speed impact with a stationary object, be it a tree, rock, pylon or another skier. Head injuries are often associated.

KNEE INURIES

The knee remains the most common single area to be injured when alpine skiing, accounting for between 30-40% of all injuries. These usually involve the medial collateral ligament, anterior cruciate ligament (ACL), the meniscus (cartilage) or any combination of the three. An ACL injury in active individuals often requires surgical treatment for optimal outcome. The meniscus or cartilage padding of the knee can also be injured while skiing. This is usually caused in a twisting weightbearing injury to the knee.

General Symptoms

- A degree of swelling is almost inevitable with most injuries, usually developing within twenty-four hours of injury. The appearance of significant swelling within the first two hours of injury suggests a serious injury to a ligament.
- An accurate description of the accident will suggest the diagnosis in the majority of cases. The direction in which the lower leg moves in the fall will dictate which structures are involved. The skier's velocity will probably influence the severity of the injury sustained.

General Treatment

- **Rest, Ice, Compression, Elevation, Stabilization**
- Splint and transport- Immobilize above and below injured joint
- Assessment of ligament stability once acute pain has settled, using the uninjured side for comparison if necessary

MCL Injuries

Torn medial collateral ligaments are the most common injury in skiing, accounting for 20-25% of all injuries. Most commonly affects beginner and low-intermediate skiers. The skiers are usually in the "snowplow" position with their knee joint internally rotated. Injury results from excessive force being applied to the knee joint, either as the result of a fall, the skis crossing, or the snowplow stance widening. In more proficient skiers, usually occurs as a result of unexpectedly catching an edge.

Symptoms

- The diagnosis is made by the description of the fall. Examination reveals tenderness over the medial collateral ligament and pain on weight bearing.
- Immediately after the fall, pain usually precludes accurate assessment of ligament stability. When possible, this should be performed by applying valgus stress to the knee with the knee in 30° flexion and the foot in internal rotation.

Treatment

- Immobilize joint in position of function
- Splint
- Apply snow to reduce swelling

ACL Injuries

Torn ACL's make up 10-15% of all ski injuries. The cause of these injuries is directly related to specific type of fall. This fall has been termed the "phantom-foot" fall. It occurs when the tail of the downhill ski in combination with the stiff back of a ski boot, acts as a lever to apply a unique combination of twisting and bending force across the knee joint. The National Ski Patrol as done video analysis of more than 14,000 skiing and racing injuries and has identified profile that characterizes this mechanism of injury.

The Phantom Foot Fall

When all six elements of the phantom foot profile are present, injury to the ACL of the downhill leg is extremely likely.

- 1) Uphill arm back
- 2) Skier off balance to the rear
- 3) Hips below the knees
- 4) Uphill ski un-weighted
- 5) Weight on the inside edge of downhill ski tail
- 6) Upper body facing downhill ski

Symptoms

- Victim feels or hears a 'pop' or a 'snap', with the knee giving way beneath.
- Question the patient about the fall- listen for characteristics indicating the "phantom foot" fall.

Treatment

- Immobilize joint in position of function
- Splint
- Apply snow to reduce swelling
- Transport

UPPER-EXTREMITY INJURIES

There are four main upper-extremity injuries common to skiers: dislocated shoulders, fractured humerus, injured thumbs, and injured wrists.

Dislocated Shoulder

Shoulder dislocations often occur as a result of a fall onto an outstretched hand. Most can be diagnosed clinically.

Symptoms

- This diagnosis is largely clinical - the patient is usually supporting the affected arm and is in great pain. The normal rounded contour of the shoulder is lost and palpation reveals that the humeral head is not sitting where it should be.

Treatment

- If appropriate, reduce the dislocated shoulder by having the patient lay prone and extend the injured arm out towards you. Clasp the patient's hand and gently pull traction as you walk in an arc from the person's hip around to above their head so that you are holding the arm above their head. This should reduce the shoulder.
- Rest the arm in a sling.
- Use snow to reduce swelling if hypothermia is not threatening

Fractured Humerus

A fractured humerus can also result from a direct blow, but sometimes a fall onto the outstretched hand.

Symptoms

- Palpation will reveal tenderness along the line of the bone (best done gently on the inside of the arm where there is less fat and muscle to get in the way).
- These breaks can be across the shaft of the bone or off the head of the bone at the actual shoulder joint. X-rays are needed here. The worst case scenario here is someone thinking the arm is dislocated when it is not and pulling on an arm that is actually broken.

Treatment

- Sling and swath the injured arm
- Use snow to reduce swelling if there is no risk of inducing hypothermia
- Treat for open fracture as appropriate (see section on Musculoskeletal Injuries)

Thumb Injuries

Skier's thumb is one of the most common injuries to skiers skiing on hardpack. The mechanism of injury of skier's thumb is fairly simple. If a ski pole gets caught between the thumb and index fingers, a tear of one of the thumb ligaments may occur because the pole can act as a lever which places great force on the thumb joints. When a skier falls with a pole in their hand, there is a danger that they will release handle of the pole and put their hand down behind them to prevent the fall. The thumb catches the snow and the skier's weight coupled with the high speeds associated with skiing falls applies force across the joint and puts the ligament under strain. Depending on the force applied, the ligament may tear completely or partially. Fractures to the thumb can also accompany this type of fall.

Symptoms

- Tenderness is localized to the joint area, especially when stress is applied.
- Patient will complain of a deep throbbing pain
- If the ligament is completely torn it may not be very painful and the joint can be opened up considerably.

Treatment

- Splint the hand in functional position around a rolled-up Sam splint or ace bandage, so that the hand is in the position of holding a can of soda.
- Use snow to prevent swelling
- Seek definitive medical care.

HEAD INJURIES

Head injuries can vary from a minor bump on the head with no long-lasting symptoms to major life-threatening trauma, depending upon the type of impact. Most ski-related deaths involve head injury, usually after a high-speed collision with another object such as a tree, rock, pylon or other skier. Most are less serious concussions that can leave symptoms including nausea, light-headedness, poor concentration and headaches. If a more serious head injury is suspected, consider immobilizing the patient's spine and evacuating to seek more definitive care.

OTHER INJURIES

Virtually any part of the body can be injured skiing. We still see so-called boot-top fractures of the tibia and fibula where either the binding fails to release, as it should, or the skier unexpectedly enters softer snow and the skis slow down but his momentum carries him forwards leading to the injury.

Spinal injuries are thankfully fairly rare but can occur after an avalanche, when a jump goes wrong or an awkward landing occurs. Important signs include pain over the spine and/or loss of feeling or function in a limb. There should always be suspicion after any high velocity accident, and movement should be kept to minimum unless victim is in immediate danger.

SNOWBOARDING

Boarding is the fastest growing snow-sport and has a different injury profile to skiing. Upper limb injuries are very common as a result of falls onto an outstretched hand. The incidence of severe wrist fractures is high and several protective devices have been produced to try and reduce the risk of wrist injury. Many boarding injuries occur when people have not taken any professional instruction.

TELEMARK SKIING

Falls in leather boots may lead to ankle sprains and fractures. The development of plastic boots has reduced this risk for both mountain touring and downhill telemarking but we recommend the use of release bindings with such boots.

BACKCOUNTRY SKIING AND AVALACHE PREPARATION

For obvious reasons, most backcountry skiers are usually very capable skiers, and fewer injuries result. There are no man-made obstacles and fewer skiers to collide with and softer snow which reduces the number of high-impact injuries. When injuries do occur, the pattern resembles that of alpine skiing. Before venturing out:

- Contact the Forest Service to obtain the most recent avalanche risk forecast
- Don't go touring alone
- Don't consider yourself an avalanche expert. Play it safe
- Let people know where you will be skiing
- Have adequate equipment
- Wear portable avalanche transceivers
- Carry avalanche shovels and probes. **Knowledge** of how to use them should be regarded as mandatory.

PREVENTION OF INJURIES

- Know your limitations. If you're a first time skier don't try a slope or run outside your range of ability.
- Use proper equipment, have bindings correctly set
- Always use eye protection (Sunglasses or Goggles)
- Wear protective gear like helmets.
- Slow down while skiing around objects or people. This helps avoid collisions.
- Never consume alcohol before taking to the slopes. It impairs judgment.

Chapter 4: Physics of the Skeleton

The Origin of Stress Generated Potential in Bone

What exactly produces potential in bone when stress is applied has been debated for almost half a century. The piezoelectric effect is found in dry bone and collagen, but is not seen in wet collagen. Another possible source called streaming potential, the forcing of an ionic fluid through a charged pore, is thought to be another mechanism of action. It may well be that there is a combined effect which produced electric potential in bones.

General Piezoelectric Effect

The piezoelectric effect is the production of an electric potential in a material by placing mechanical stress on it. The piezoelectric effect is related to symmetry, that is the more asymmetrical the higher the potential. The stress can be either direct pressure or shear. A material will respond with different potentials depending on its structure. Different components of stress, different directions or strain, can produce different components of potentials.

Piezoelectric Effect in Dry Bone

The piezoelectric effect is seen in dry bone. This was first studied in 1957, Fukada and Yasuda. They showed there is a direct linear relationship between polarization and stress. They determined it was the piezoelectric effect producing the potential by producing what is called the converse effect. The converse piezoelectric effect is deformation of the material produced by an electric field. The converse effect produces a strain in dry bone when the bone is in an electric field.

Piezoelectric Effect in Collagen

The piezoelectric effect is also present in collagen. Bone collagen is probably the source of the piezoelectric effect in bone. As with bone there is a linear relationship between potential and amount of stress, and a converse effect present. The piezoelectric constant varies with angle similar to bone.

Hydration Effects on the Piezoelectric Effect in Bone

As collagen increases in water content the piezoelectric effect decreases. At 40% hydration the piezoelectric effect becomes nonexistent. The cause of this decrease in piezoelectric effect can be explained through symmetry. As collagen hydrates it becomes more symmetrical. This is because the water forms hydrogen bonds with the collagen molecules and increases their symmetry. As the collagen becomes more symmetrical the piezoelectric effect

decreases.

It is logical to assume that because the piezoelectric effect of bone is due to bone collagen then the piezoelectric effect of bone should also decrease with water content. This is only partly true. Bone also contains hydroxyapatite crystals that are bound to the collagen molecules. These crystals are not piezoelectric because they are centro-symmetrical. They reduce the number of sites that water can bind to the collagen. Another effect they have is that they stiffen the collagen and prevent it from expanding so it cannot take up as much water. The restriction of these crystals results in bone only being able to hydrate to 26% water content. 26% hydration is enough that there is a piezoelectric effect present, but not a large one.

Streaming Potential

There is another effect present in bone under stress which produces potential in bone. It is called the streaming potential. To understand this phenomena, an understanding of the structure of bone is essential. Bone contains structures called osteons. Osteons are made of a porous bone matrix.

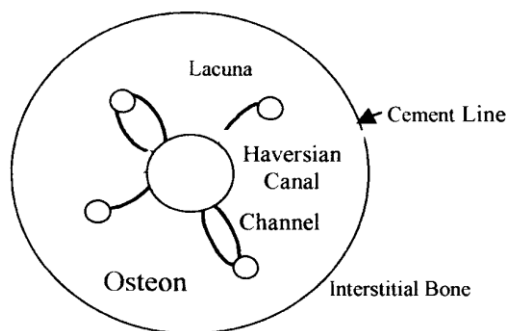

The matrix has many spaces, lacunae, each connected by channels to a central Haversian canal.

The spaces, channels, and canal are filled with an ionic fluid. The walls of the channels are made up of collagen bone matrix, which is positively charged. This positive charge attracts negative ions from the fluid. This produces two potentials, the double layer potential, and the Zeta potential: Z .⁶ The distribution of ions in the fluid isn't uniform, so there is a charge distribution, $p(r)$, r = radial distance from the center of the channel. This charge distribution creates a potential function of r . The potential gradient is from the middle of the channel to the wall, with the maximum being the Zeta Potential:

When bone is compressed, the bone fluid is forced from the compression side to the tension side. The ionic fluid flows from the lacunae through the channel across the pressure gradient to the Haversian canal. The Haversian canal is at the low-pressure end, maintaining a pressure approximate to arterial/atmospheric pressure.

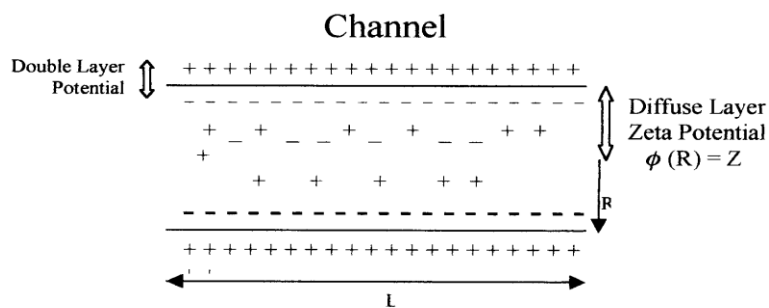

The anions are held by the positive matrix surface, leaving the cations in the fluid. When the fluid flows there is a net movement of cations, resulting in a

potential difference. The positive potential is at the low-pressure end, the Haversian canal, where the fluid end up.

Electrodynamic Effect

Because there is controversy over the existence of piezoelectric effect of wet bone there is controversy over the electrodynamic effect. When the piezoelectric effect and streaming potentials interact, the combined effect is known as the electrodynamic effect. When stress is applied to bone it changes the potential of the collagen matrix. This change results in an alteration of the double and Zeta Potentials. The streaming potentials are modified by the change in charge density.

Conclusion

An electric potential is generated in bone as a result of mechanical stress. There are two different mechanisms acting to produce this potential, the piezoelectric effect and streaming potentials. Piezoelectric effect is the generation of potential in material due to stress. Streaming potentials is the forcing of an ionic fluid through a charged pore. These are both present in bone and contribute to the generated potential. Piezoelectric effect is a minor contributor, while it appears that streaming potentials is the main mechanism for producing potential in bone.

Chapter 5: Pressure in the Body

Abdominal Pressure 105 cm H₂O

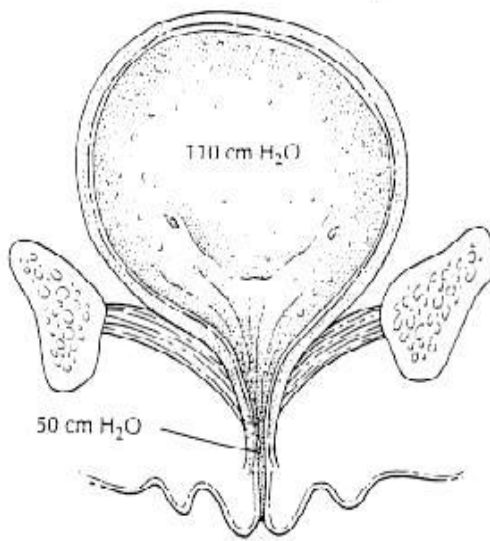

Stress Incontinence

Abdominal Pressure 105 cm H₂O

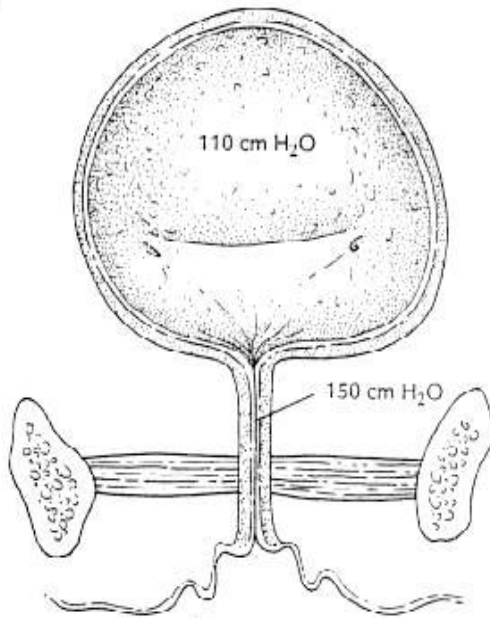

Normal, Increased Pressure

Abdominal Pressure 5 cm H₂O

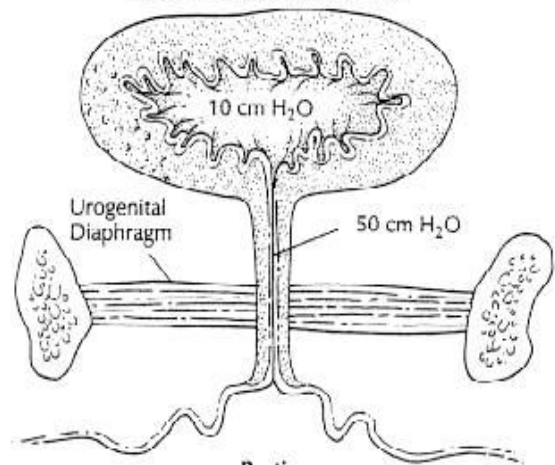

Resting

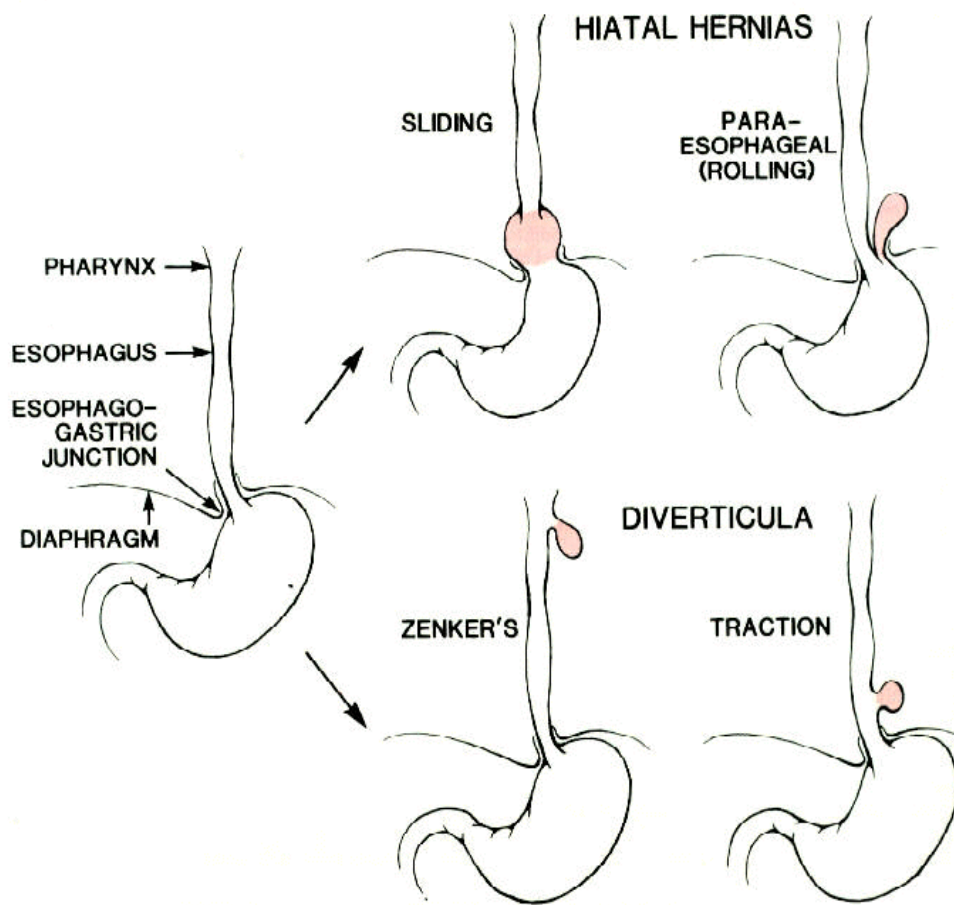

Chapter 7: Physics of the Lungs and Breathing

LUNG VOLUME DIAGRAMS

Lung volume diagrams show a forced expiration from maximum inspiration using a device called a spirometer. There are four basic functional volumes of which the lung is made. These are shown on the graph. A "capacity" is equal to 2 or more of these basic volumes. In severe chronic obstructive pulmonary disease (COPD), the total lung capacity is normal or increased (even although vital capacity is decreased) due to a greatly increased residual volume. In restrictive lung disease, the Total Lung Capacity is decreased as are the Vital Capacity and Reserve Volume.

During normal breathing at rest we inhale about 500 cm^3 of air with each breath. This is referred to as the *tidal volume at rest*. At both the beginning and end of a normal breath there is considerable reserve. At the end of a normal inspiration it is possible with some effort to further fill your lungs with air. The additional air taken in is called the *inspiratory reserve volume*. Similarly, at the end of a normal expiration you can force more air out of your lungs. This additional expired air is called the *expiratory reserve volume*. The air remaining in the lungs after a normal expiration is called *the functional residual capacity (FRC)*. It is this stale air that mixes with the fresh air of the next breath. During heavy exercise, the tidal volume is considerably larger. You have a fair idea of your lung capacity if you have ever blown up a paper sack or an air mattress. If a person breathes in as deeply as possible and then exhales as much as

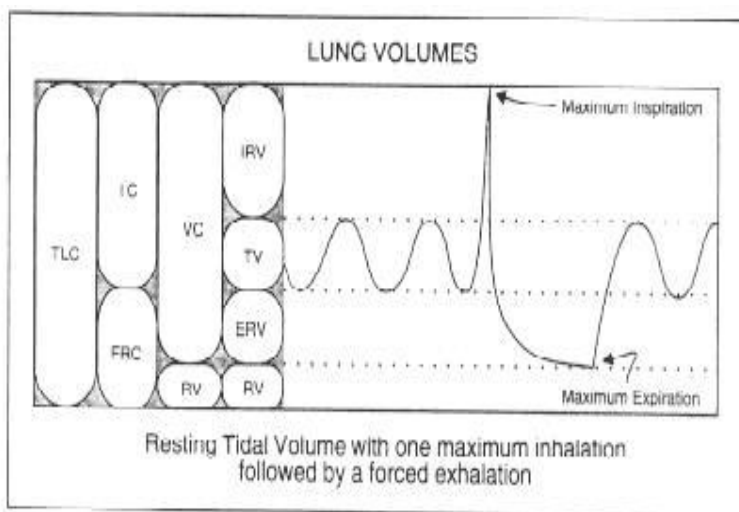

TLC = total lung capacity; RV = residual vol; ERV = expiratory reserve vol; TV = tidal vol; IRV = insp reserve vol; IC = insp capacity; VC = vital capacity. If you see FVC, it is just the VC during a Forced expiration.

possible the volume of air exhaled is called the *vital capacity*. However, the lungs will still contain some air the *residual volume*, which is about one liter for an adult. The residual volume can be determined by having the subject breathe in a known volume of an inert gas such as helium and then measuring the fraction of helium in the expired gas. Since the helium and air will mix thoroughly during a single breath, this dilution

technique is quite accurate.

A number of clinical tests can be made with the spirometer. The amount of air breathed in one minute is called the *respiratory minute volume*. The maximum volume of air that can be breathed in 15 s is called the *maximum voluntary ventilation* and is a useful clinical quantity. The maximum rate of expiration after a maximum inspiration is a useful test for emphysema and other obstructive airway diseases. In some cases the flow rate decreases with excessive expiratory effort. A normal person can expire about 70% of his vital capacity in 0.5 s, 80% in 1.0 s, 94% in 2.0 s, and 97% in 3.0 s. Normal peak flow rates are 350 to 500 liters/min. The velocity of the expired air can be impressive; if a person coughs or sneezes hard without covering his mouth, the velocity of the air in his trachea can reach Mach 1 the velocity of sound in air. This high velocity can cause partial collapse of the airways because of the *Bernoulli effect*.

Not all of the air we inspire adds O_2 to the blood. The volume of the trachea and bronchi is called the *anatomic dead space* since air in this space is not exposed to the blood in the pulmonary capillaries. Typically the anatomic dead space is about 150 cm^3 . In addition, in some diseases some of the alveolar capillaries are not perfused with blood and the O_2 is not absorbed in these alveoli. This unused volume is called *physiologic* or *alveolar dead space*. Air in the dead space does not provide any O_2 to the body. The air in the anatomic dead space after an expiration is taken back into the lungs during the next inspiration. If you increase your dead space by breathing through a long tube, you will recycle more of your own breath. If the tube has a volume equal to your vital capacity you obviously will get no new air and will suffocate.

FORCED EXPIRATORY VOLUMES

It is possible to have a patient force air from the lungs and make a tracing of this. This creates what is called a Forced Expiratory Volume chart. The diagrams below show a comparison of expirations for normal, obstructive, and restrictive airway patients. This is an easy and important test. Although the Total Lung Capacity cannot be determined from spirometry (since we must know the Residual Volume first), the degree of obstruction can be determined by comparing the forced volume expired at one second (FEV_1) to the forced vital capacity in the ratio FEV_1/FVC (FVC is just the VC during a forced expiration). In a patient with a normal lung, the ratio is about 0.8. It is always less in a COPD patient or an asthma patient having an acute attack, but may be *normal or increased* in a patient with restrictive disease even though the VC is small. A patient with asthma has reversible disease and may have a normal FEV_1/FVC if not having an acute attack.

FLOW VOLUME LOOPS

The Flow-Volume loops shown below are another common way of expressing air flow in the different lung diseases-again just using the spirometry data. Note that the y-axis is flow *rate*.

Because we do not know RV, we get most of our information by the *shape* of the loop. The exception is in restrictive disease; the shape is similar to normal but the vital capacity (which equals TLC - RV) is much smaller than normal.

In analyzing an obstructive disease of the *upper airway* (from the pharynx to the mainstem bronchi), much information can be derived from the *shape* of the flow-volume loop. If the upper airway obstruction is *fixed*, the graph is flattened on the top *and* the bottom; i.e. during both inspiration and expiration. Examples of fixed obstruction are conditions due to compressive

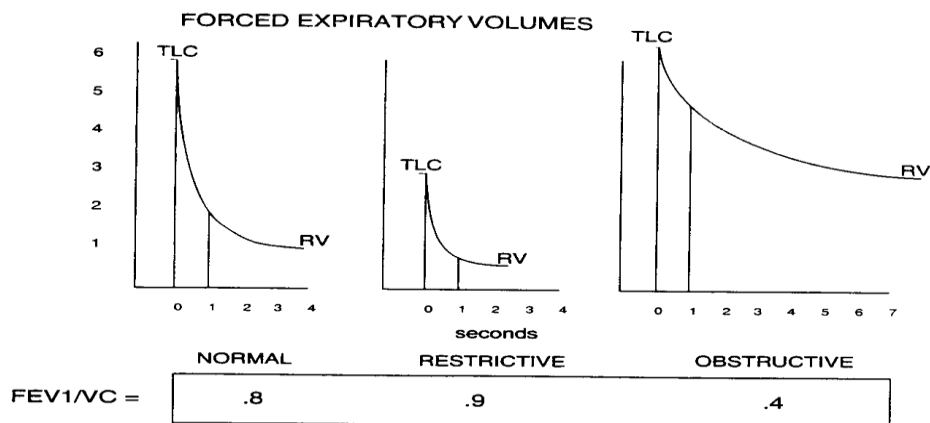
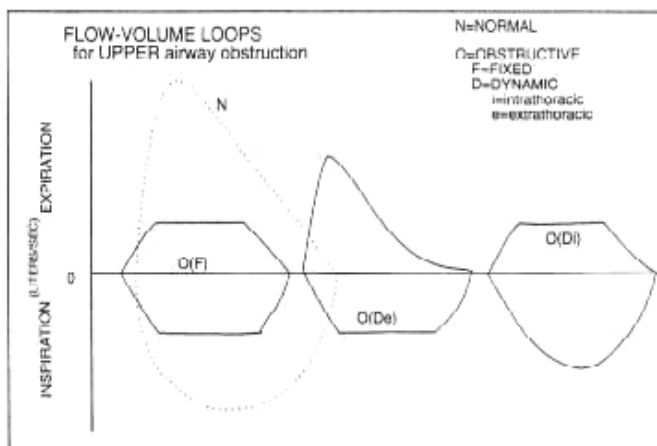
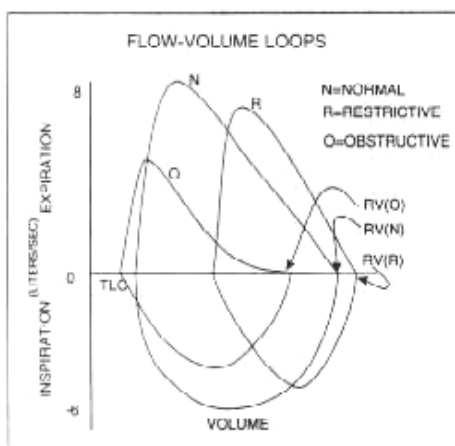

tumors (e.g. thyroid tumors) and tracheal stenosis. With *dynamic* extrathoracic obstruction, such as in tracheomalacia and vocal cord paralysis, the obstruction occurs on inspiration. If the tracheomalacia is intrathoracic, the flow is impeded on expiration due to increased intrathoracic pressure pressing on the malacic trachea

Chapter 8: Physics of the Cardiovascular System

Afterload and Preload

If you take a single muscle fiber and place a weight on it, the muscle fiber will stretch a certain distance. The weight on the muscle fiber that stretches it that distance is called the **preload** (P) of that muscle. So the preload is the load that stretches a cardiac muscle fiber to a new length. The preload is directly proportional to the stretch of the muscle. Now, a clamp is

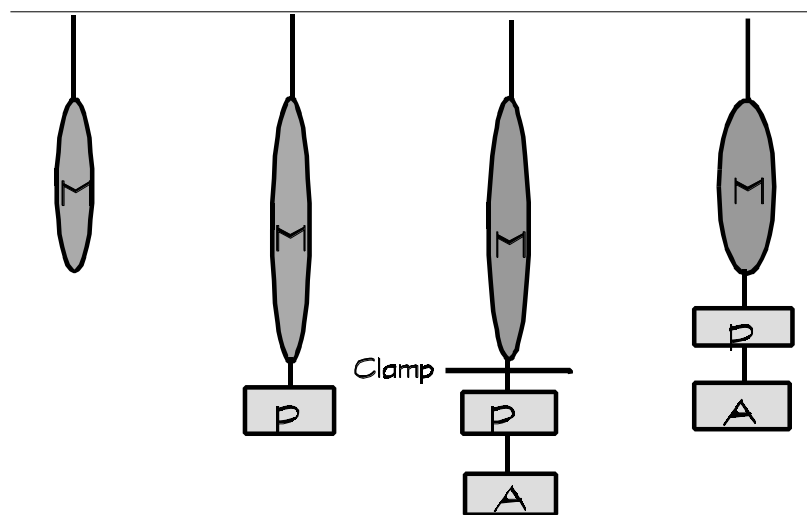

placed on the muscle fiber, so that it can neither stretch any further, or contract. A second weight is now placed on that fiber. Now an electrical stimulus to the muscle at the same time the clamp is released, The muscle fiber contracts, lifting both weights. The weight that must be lifted is called the **afterload**. The ability of the muscle to lift both weights is an index of strength of muscle contraction and the term used to describe this force is **contractility**.

The Cardiac Cycle

1. The left ventricle begins to fill at point A, when the mitral valve opens and blood rushes in from the left atrium. The volume in the ventricle increases progressively until the pressure in the

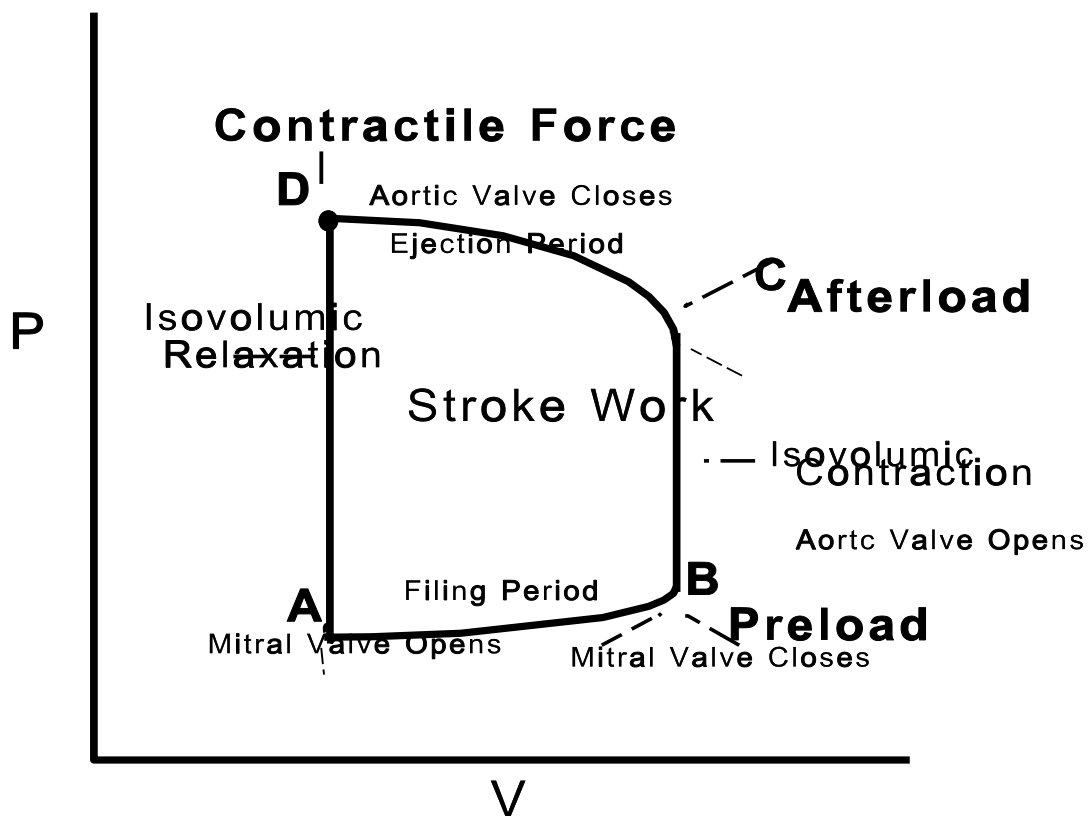

chamber exceeds left atrial pressure and the mitral valve closes (point B). The volume in the ventricle at this point is the end-diastolic volume. This volume is analogous to preload weight in the muscle model because it will stretch the ventricular muscle to a new resting (diastolic) length. In other words, **end diastolic volume is equivalent to preload.**

2. At point B, the ventricle begins to contract while both aortic and mitral valves are closed

(isovolumic contraction.). The chamber pressure quickly rises until it exceeds the pressure in the aorta and forces the aortic valve to open (point C). The pressure at this point is analogous to the afterload weight in a muscle model because it is imposed on the ventricle after the onset of contraction (systole), and is a force that must be overcome before the ventricle can eject the stroke volume. Therefore **diastolic pressure is afterload**.

3. Once the aortic valve opens, the stroke volume is ejected into the aorta (along the horizontal axis) from point C to point D. When the pressure in the ventricle falls below the aortic pressure, the aortic valve will close at point D. The contractile force of the ventricle determines the volume of blood ejected along the horizontal axis at a given preload and afterload. In other words, the pressure at point D will be a function of contractility when point B (preload) and point C (afterload) are constant. In other words, **the systolic pressure is equivalent to contractility**.

4. When the aortic valve closes at point D, the ventricular chamber pressure falls precipitously (isovolumic relaxation) until the mitral valve opens again at point A and the cycle begins again.

5. The area within the pressure-volume loop defines the work performed by the ventricle during one cardiac cycle.

The Starling Curve

The output of the normal heart is influenced primarily by the volume of blood in the ventricles at the end of diastole. This was first described in 1885 and then studied again in 1915. Ernest Starling and Otto Frank determined that there was a relation between end diastolic volume and systolic pressure. Note the steep ascending portion of the curve. It indicates the importance of preload (volume) for augmenting the output of the normal heart. The greater the preload (volume) the greater the cardiac output.

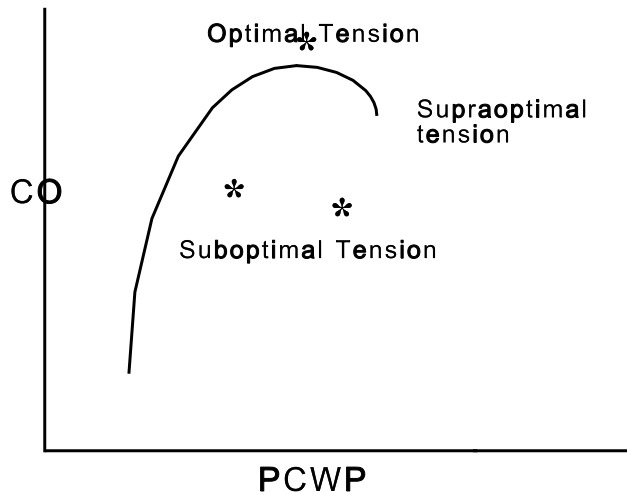

As can be seen there is a point at which optimal stretch is developed. However, as cardiac muscle stretches too far, the pressure (muscle tension) falls off, creating a decline in developed tension and thus cardiac output. The ability to control cardiac output is essential for proper management of a diseased heart or body.

Arterial Pulse

The blood forced in the aorta during systole not only moves the blood in the vessels

forward but also sets up a pressure wave that travels along the arteries. The pressure wave expands the arterial walls as it travels, and the expansion is palpable as the *pulse*. The rate at which the waves travels, which is independent of and much higher than the velocity of blood flow, is about 4 m/s in the aorta, 8 m/s in the large arteries, and 16 m/s in the small arteries of young adults. Consequently, the pulse is felt in the radial artery at the wrist about 0.1 seconds after the peak of systolic ejection into the aorta. With advancing age, the arteries become more rigid and the pulse wave moves faster.

The strength of the pulse is determined by the pulse pressure and bears little relation to the mean pressure.

The pulse is "weak" if blood volume is low or contractility is low. It is strong when stroke volume is large such as during exercise. When the aortic valve is incompetent, the pulse is particularly strong and the force of systolic ejection may be sufficient to make the head nod with each heartbeat.

The dicrotic notch is a small oscillation on the falling phase of the pulse wave caused by vibrations set up when the aortic valve snaps shut. It is visible if the pressure wave is recorded on a monitor, but not palpable at the wrist.

Atrial Pressure and the Jugular Pulse

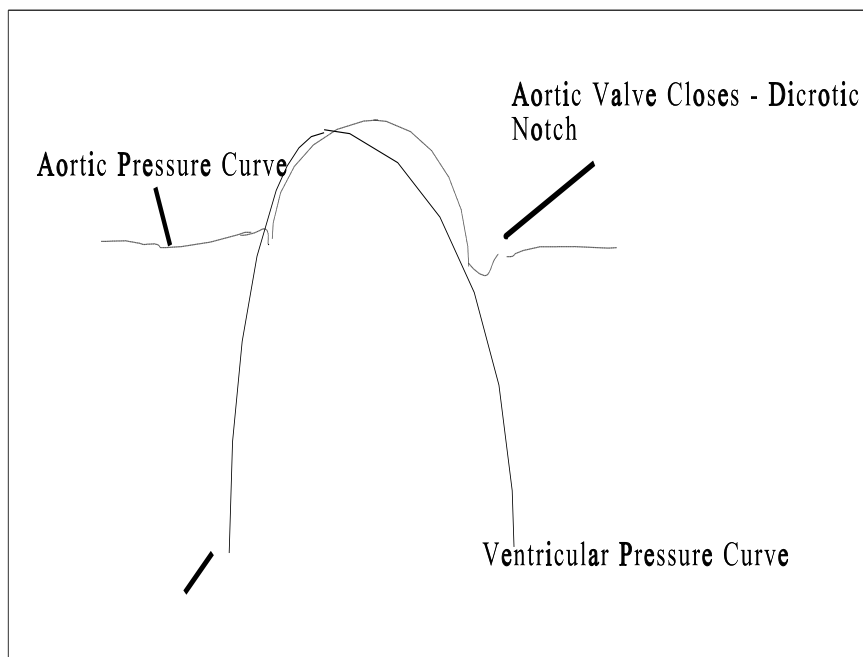

Atrial pressure rises during atrial systole and continues to rise during isovolumetric ventricular contraction when the AV valves bulge into the atria. When the AV valves are pulled down by the contracting ventricular muscle, pressure falls rapidly and then rises as blood flows into the atria until the AV valves open early in diastole. The return of the AV valves to their relaxed position also contributes to the pressure rise by reducing atrial capacity. The atrial pressure changes are transmitted to the great veins producing 3 characteristic waves in the jugular pulse. The *a wave* is due to atrial systole. As noted above, some blood regurgitates into the great veins when the atria contract, even through the orifices of the great veins are constricted. In addition, venous inflow stops, and the resultant rise in venous pressure contributes to the *a wave*. The *c wave* is the transmitted manifestation of the rise in atrial pressure produced by the bulging of the tricuspid valve into the atria during isometric ventricular contraction, the *v wave* mirrors the rise in atrial pressure before the tricuspid valve opens during diastole. The jugular pulse waves are superimposed on the respiratory fluctuations in venous pressure. Venous pressure falls during inspiration as a result of the *increased negative intrathoracic pressure* and rises again during expiration.

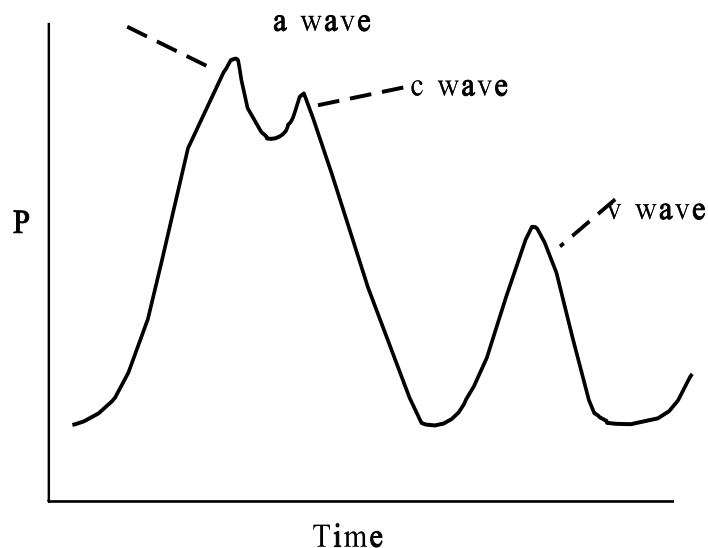

Some Useful Explanations

Cardiac Output

The amount of blood circulated by the heart expressed in liters/minute. Normally 3.5-4.5 liters/minute. It is equal to heart rate times stroke volume ($H.R. \times S.V. = C.O.$) Cardiac output can be approximated from the arteriovenous oxygen ($A-VO_2$) difference(see below), but can be determined exactly using a pulmonary artery catheter with a thermistor at the end.

Cardiac Index

Probably more useful than cardiac output, it account for body size and is calculated by dividing cardiac output by body surface area, expressed in $L/min/m^2$. Normal in adults is 2.8 to 3.2 $L/min/m^2$.

Stroke Volume

The amount of blood pumped by the heart with each cardiac cycle. Stroke volume is determined by preload, afterload, and contractility.

Preload

This is the amount of stretch on the myocardial fibers at the end of diastole. As the stretch increases, the energy of contraction increases proportionally until an optimal tension is developed. However, Starling's Law states that the developed tension increases to a maximum, and then further stretch beyond the optimal tension, causes decline in the developed tension.

Afterload

Defined as the resistance to ventricular ejection, due to resistance to flow in the arterial tree. The clinical measurement of the afterload is the system vascular resistance.

Contractility

The ability of the heart to alter its contractile force and velocity independent of the fiber length. It represents the intrinsic strength of individual muscle fiber cells.

PCWP

Pulmonary capillary wedge pressure reflects left atrial pressure. It is measured by a pulmonary catheter, and in the absence of pulmonary vascular disease, the pressure in the pulmonary artery after occlusion by the balloon tip, will approximate the pressure in the left atrium. In the absence of mitral valve disease, the pressure in the left atrium is about the same as the left ventricular end diastolic pressure. Thus PCWP should correlate directly with cardiac preload, since end diastolic pressure (from the wedge pressure) is proportional to end diastolic volume (which indicates preload).

A-VO₂ Difference

The arteriovenous oxygen difference measures the difference between the oxygen content of the arterial blood and the oxygen content of mixed venous blood. Thus, this reflects the ability of the peripheral tissues to extract oxygen from blood. Therefore, the A-VO₂ difference is inversely proportional to cardiac output. If the cardiac output is low, transit time is long and the tissues will extract large amounts of oxygen during a single circulation time, giving a large A-VO₂ difference. If cardiac output is high, transit time is short, giving tissues less opportunity to extract oxygen. Consequently, the A-VO₂ difference will be small.

SvO₂

This is the hemoglobin concentration in mixed venous blood. It is called mixed since it is a combination of $\text{A}_{\text{oxygenated}}$ and $\text{A}_{\text{unoxygenated}}$ blood. Again, this is a measure of cardiac output. A transducer is placed in a large vein. In a normal resting adult this number is around 75% or greater. That is, the tissue of a person at rest will utilize about 25% of the available oxygen. If the cardiac output is low, then the tissue will have more time to extract oxygen from the blood and this number will drop.

The Cardiac Cycle

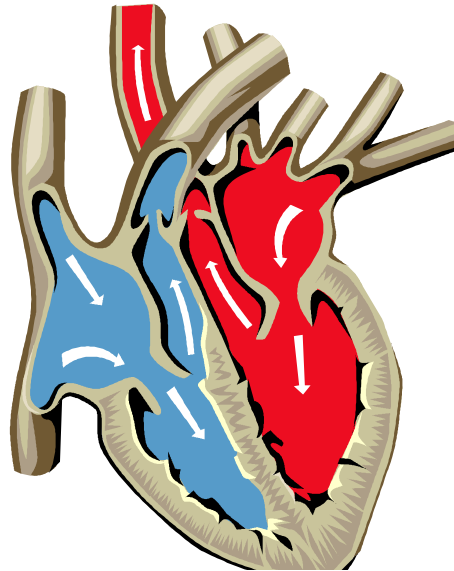

Chapter 11: Physics of the Ear and Hearing

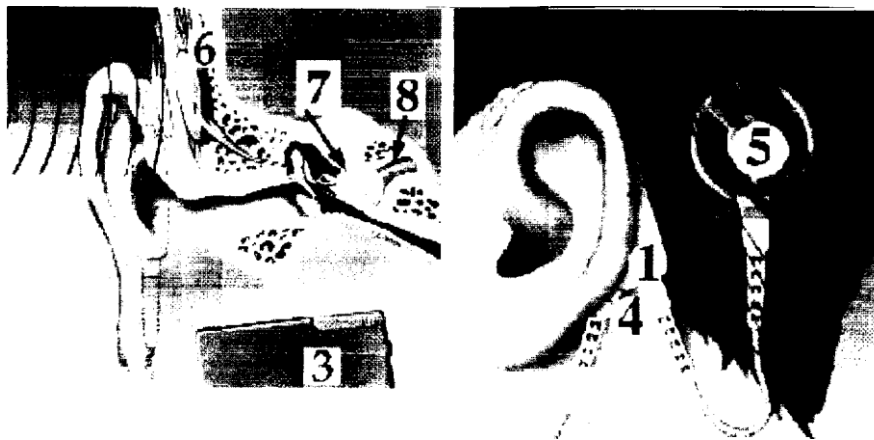

COCHLEAR IMPLANTS

Loss of hearing is America's most prevalent, yet least recognized physical ailment. Worldwide, approximately one person in a thousand is born deaf. Almost an equal number of people born with hearing will develop deafness during their lifetime. To combat this, one of the most rapid advances in medical technology is currently in the field of cochlear implants. Today, over 12,000 adults and children worldwide have received a cochlear implant.

The ear is divided into the external, the middle, and the inner ear. Each of these three parts performs an important function in the process of hearing. Sound travels along the ear canal of the external ear and causes the ear drum to vibrate. The three small bones of the middle ear conduct this vibration from the eardrum to the cochlea. Fluid waves in the cochlea, initiated by movement of the three small ear bones, stimulate the more than sixteen thousand delicate hair cells. Movement of these hair cells generates an electrical current in the auditory nerve fibers. Finally, this current is transmitted through various complicated interconnections in the brain stem to the auditory cortex, which recognizes this electrical stimulation as sound.

When there is disease or obstruction in the external or middle ear, a conductive hearing impairment results. This impairment may be due to a variety of problems and may be corrected by medical or surgical treatment. When the hearing impairment is due to a problem in the inner ear, nerve deafness results. In most cases of nerve deafness, the hair cells have been damaged and do not function. Although many of the auditory nerve fibers may be intact and capable of transmitting electrical impulses to the brain, without functioning hair cells the nerve fibers become obsolete.

Cochlear implants are designed to bypass the hair cells which are not functioning and provide stimulation directly to the auditory nerve. Although there are a number of different cochlear implants in use around the world, they all have certain basic aspects in common. The various components are: an electrode array, (1) a receiver for the electrode array, (2) a sound processor, (3) a small electronics package that typically is placed in the wearer's pocket, (4) a transmitting coil and (5) the microphone. There are several basic steps in which the cochlear implant functions. First, sound is received by a microphone that rests over the ear like a behind-the-ear hearing aid. This sound is then sent from the microphone to the signal processor by a thin cable. After that, the sound processor amplifies, filters, and digitizes the sound into a distinct electrical code. Sound processors can store three user-defined computer programs, often referred to as "maps." Maps store different information related to loudness levels, listening thresholds, or stimulating waveforms. Because of this, users can change programs to accommodate different listening environments by simply turning a small knob on the speech processor.

In the normal ear, the traveling wave functions to separate the frequency components of speech. This attribute of frequency analysis and differential excitation is what the sound processing system attempts to simulate. An automatic gain control (AGC) circuit controls the gain and amount of compression to keep the amplitude of the electrical signal within the range of the electronic processing capability, and comfort range of the patient. After that, the input signal is band passed, then converted to current with a voltage to current converter.

In the next step, these electrical signals are sent from the sound processor to the transmitting coil via a thin cable. This transmitting coil is held to the scalp by its attraction to a magnet implanted beneath the skin. After that, a transmitter sends the signal codes across the skin to a receiver/stimulator implanted in the mastoid bone. The cycle of taking in sound, and converting it to electrical impulses to stimulate specified electrodes at specified intensities is quite rapid, the newer systems can send information at a rate of 91,000 times per second. Once the receiver/stimulator obtains the electrical signals it delivers them to the appropriate electrodes on the array. The lowest filter, channel one, corresponds to the most apical electrode used, and the highest filter, channel four, corresponds to the most basal electrode used. Each channel is adjusted as indicated by the subject's sound field thresholds to obtain as close to a flat audiogram as possible. The spiral electrode array fits the natural curve of the cochlea, and is usually inserted through the round window. It is inserted approximately 24 mm into the cochlea.

The electrode array consists of up to 22 electrodes arranged in staggered pairs. The electrode pairs represent the positive and negative polarity contacts between which electric current flows. The stimulating waveforms pass through the electrodes allowing the electrical stimulus to bypass the damaged or missing hair cells and directly stimulate the remaining auditory nerve fibers. This configuration allows for selective stimulation of discrete segments along the cochlea, thus providing greater pitch discrimination than single channel cochlear implants. The word 'channels' is used to designate the number of electrode pairs that are conveying different stimulus waveforms. Different stimulus waveforms will excite neurons in different ways. Typically, the number of channels equals the number of electrode pairs.

Finally, the resulting electrical sound information is sent through the auditory nerve fibers to the brain for interpretation. Because there are only 22 electrodes possible in a cochlear

implant, these few points of stimulation cannot even compare with the 15,000 ear hair cells that sense sound in the normal inner ear. Because of this, the majority of totally deaf patients who receive a cochlear implant can detect medium to loud sounds, but they can not always interpret them. Eventually, however, many users can learn to recognize some familiar sounds such as approaching footsteps, and doors opening and. In addition, for many patients, cochlear implants aid in communication by improving lip-reading ability.

A paper on cochlear implants would not be complete without mentioning its critics. Many people who use sign language as their primary means of communication are opposed to the devices, especially for children. They consider them an insult and a threat to their culture. The technology, according to these opponents, represents a condemnation of deafness, and an attempt to fix something that they do not consider in need of fixing. Instead, they are proud of their culture, which they have built around deafness. In defending that culture, a Canadian Deaf culture association has called the use of cochlear implants in children a form of ethnic purification and genocide, as well as emotional and mental abuse.

Although cochlear implants are on the cutting edge of modern technology, there is no question that they still need improvement. Hopefully, in the future, devices will become more sophisticated, and new processing strategies will be developed that are even more effective than those of today. In addition, therapists and audiologists will improve their ability to custom fit and fine-tune the setting for a person's cochlear implant to allow everyone to get the best benefit out of their devices. With these improvements, perhaps the opposition to these implants will lessen so they will be seen as a powerful system of adaptive technology that can help some deaf persons to adapt to a hearing environment.

Chapter 13: Medical Imaging and the Treatment of Cancer

X-rays

Since their discovery in 1895, X-rays have played an important role in medical treatment. Their usefulness was obvious from the very evening they were discovered. It was November- 8 and German physicist Wilhelm Conrad Roentgen (1845-1923) was experimenting with an electric discharge in a vacuum tube. He had covered the entire tube in black cardboard and was working in a darkened room. Some distance from the tube a phosphored screen began to glow. Some kind of radiation was being released by the tube, passing through the cardboard and the air, and causing the screen to fluoresce. Roentgen put various objects in the way of the radiation but they didn't block the flow. Finally, he put his hand in front of the screen and saw a shadowed image of his bones. He had discovered X-rays and their most famous application at the same time.

The first clinical use of X-rays was on January 13, 1896, when two British doctors used them to find a needle in a woman's hand. In no time, X-ray systems became common in hospitals as a marvelous new technique for diagnosis. But this imaging capability was not without its side effects. Although the exposure itself was painless, overexposure to X-rays caused deep burns and wounds that took some time to appear. Evidently the X-rays were doing something much more subtle to the tissue than simply heating it.

X-rays are a form of electromagnetic radiation, as are radio waves, microwaves, and light. These different forms of electromagnetic radiation are distinguished from one another by their frequencies and wavelengths-while radio waves have low frequencies and long wavelengths, X-rays have extremely high frequencies and short wavelengths. But they are also distinguished by the energies carried in their photons. Because of its low frequency, a radio wave photon carries little energy. A medium frequency photon of blue or ultraviolet light carries enough energy to rearrange one covalent bond in a molecule. But a high frequency X-ray photon carries so much energy that it can break many covalent bonds and rip molecules apart.

In a microwave oven, the microwave photons work together to heat and cook food. The amount of energy in each microwave photon is unimportant because they don't act alone. But in radiation therapy, the X-ray photons are independent. Each one carries enough energy to damage any molecule that absorbs it. That's why X-ray burns involve little heat and appear long after the exposure-the molecular damage caused by X-rays takes time to kill cells.

Making X-Rays

Medical X-ray sources work by crashing fast-moving electrons into heavy atoms. These

collisions create X-rays via two different physical mechanisms: bremsstrahlung and X-ray fluorescence.

Bremsstrahlung occurs whenever a charged particle accelerates. This process is nothing really new, since we know that radio waves are emitted when a charged particle accelerates on an antenna. But in a radio antenna, the electrons accelerate slowly and emit low energy photons. Bremsstrahlung usually refers to cases in which a charged particle accelerates extremely rapidly and emits a very high energy photon. In X-ray tube bremsstrahlung, a fast-moving electron arcs around a massive nucleus and accelerates so abruptly that it emits an X-ray photon.

When a fast moving electron arcs around a massive nucleus, it accelerates rapidly. This sudden acceleration creates a bremsstrahlung X-ray photon, which carries off some of the electron's energy.

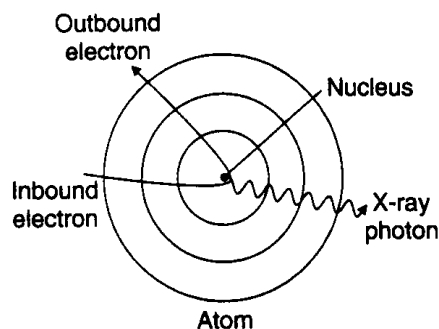

This photon carries away a substantial fraction of the electron's kinetic energy. The closer the electron comes to the nucleus, the more it accelerates and the more energy it gives to the X-ray photon. However the electron is more likely to miss the nucleus by a large distance than to almost hit it, so bremsstrahlung is more likely to produce a lower energy X-ray photon than a higher energy one.

In **X-ray fluorescence**, the fast-moving electron collides with an inner electron in a heavy atom and knocks that electron completely out of the atom.

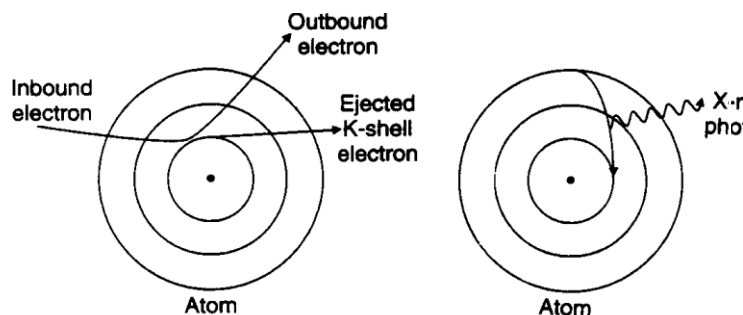

When a fast moving electron collides with an electron in one of the inner orbitals of a heavy atom, it can knock that electron out of the atom. An electron from one of the atom's outer orbitals soon drops into the empty orbital in a radiative transition that creates a characteristic X-ray.

This collision leaves the atom as a positive ion, with a vacant orbital close to its nucleus. An electron in that ion then undergoes a radiative transition, shifting from an outer orbital to this

empty inner one and releasing an enormous amount of electrostatic potential energy in the process. This energy emerges from the atom as an X-ray photon. Because this photon has an energy that's determined by the ion's orbital structure, it's called a **characteristic X-ray**.

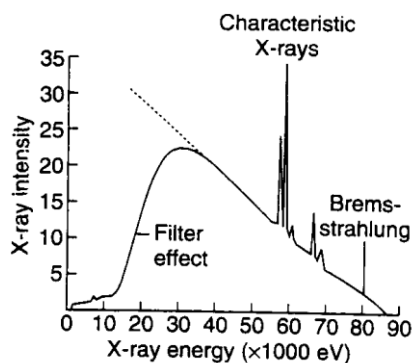

When electrons with 87,000eV of energy collide with tungsten metal, they emit X-rays via bremsstrahlung and X-ray fluorescence. While the bremsstrahlung X-rays have a broad range of energies, an absorbing filter blocks the low energy ones. X-ray fluorescence produces characteristic X-rays with specific energies.

To discuss the energies carried by X-ray photons, we need an appropriate energy unit. While the joule is a useful unit of energy for describing collisions between bats and balls, it's too big to be practical for X-rays and collisions of subatomic particles. Instead, we'll use **electron-volts** (abbreviated eV). 1 eV (1 electron-volt) is about 1.602×10^{-19} J and is the amount of kinetic energy an electron acquires as it accelerates through a voltage difference of 1 V.

Photons of visible light carry energies of between 1.6 eV (red light) and 3.0 eV (violet light). Because the ultraviolet photons in sunlight have energies of UP to 7 eV, they are able to break chemical bonds and cause sunburns. But X-ray photons have much larger energies than even ultraviolet photons.

In a typical medical X-ray tube, electrons are emitted by a hot cathode and accelerate through vacuum toward a positively charged metal anode.

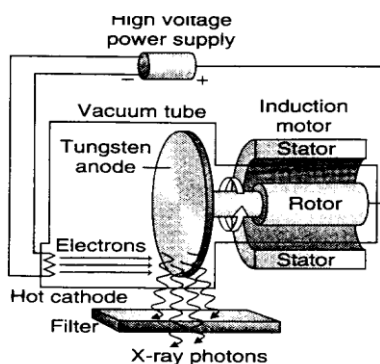

In a medical x-ray machine, electrons from a hot filament accelerate toward a positively charged metal disc.. They emit X-rays when they collide with the disc=s atoms. To keep the disk from melting, it=s spun by an induction motor. The filter absorbs useless low energy X-rays.

The anode is a tungsten or molybdenum disk that is spun rapidly by an induction motor to keep it from melting. The energy of the electrons as they hit the anode is determined by the voltage difference across the tube. In a medical X-ray machine, that voltage difference is typically about 87,000 V, so each electron has about 87,000 eV of energy. Since an electron gives a good fraction of its energy to

the X-ray photon it produces, the photons leaving the tube can carry up to 87,000 eV of energy. No wonder X-rays can damage tissue. When the electrons collide with a target of heavy atoms, they emit both bremsstrahlung and characteristic X-rays.

The characteristic X-rays have specific energies so they appear as peaks in the overall X-ray spectrum. The bremsstrahlung X-rays have different energies but are most intense at lower energies. Because lower energy X-ray photons aren't useful for imaging or radiation therapy and injure skin, medical X-ray machines use absorbing materials, such as aluminum, to filter them out.

Using X-Rays

X-rays have two important uses in medicine: imaging and radiation therapy. In X-ray imaging, X-rays are sent through a patient's body to a sheet of film or an X-ray detector. While some of the X-rays manage to pass through tissue, most of them are blocked by bone. The patient's bones form a shadow image on the **film** behind them. In X-ray radiation therapy, the X-rays are again sent through a patient's body, but now their interaction with diseased tissue is what's important. The X-rays deposit some of their energy in this tissue and kill it.

X-ray photons interact with tissue and bone through four major processes: *elastic scattering, the photoelectric effect, Compton scattering, and electron-positron pair production*. **Elastic scattering** is already familiar to us as the cause of the blue sky—an atom acts as an antenna for the passing electromagnetic wave, absorbing and re-emitting it without extracting any of its energy.

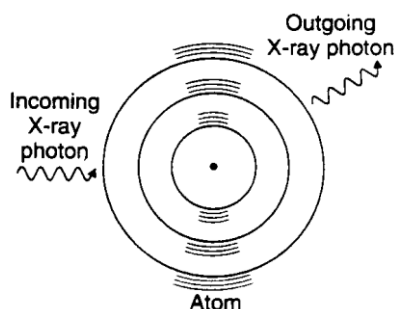

When an X-ray photon scatters elastically from an atom, the whole atom acts as an antenna. The passing photon jiggles all of the charges in the atom and these charges absorb the photon and re-emit it in a new direction

Because this process has almost no effect on the atom, elastic scattering isn't important in radiation therapy. However, it's a nuisance in X-ray imaging because it produces a hazy background—some of the X-rays passing through a patient bounce around like pinballs and arrive at the film from odd angles. To eliminate these bouncing X-ray photons, X-ray machines use filters that block X-rays that don't approach the film from the direction of the X-ray source.

The **photoelectric effect** is what makes X-ray imaging possible. In this effect, a passing

photon induces a radiative transition in an atom—one of the atom's electrons absorbs the photon and is tossed completely out of the atom. If the atom were using the X-ray photon to shift an electron from one orbital to another, that photon would have to have just the right amount of energy. But because a free electron can have any amount of energy, the atom can absorb any X-ray photon that has enough energy to eject one of its electrons. Part of the photon's energy is used to remove the electron from the atom and the rest is given to the emitted electron as kinetic energy.

In the photoelectric effect, an absorbed photon ejects an electron from an atom. Part of the photon's energy is used to remove the electron from the atom and the rest becomes kinetic energy in the electron.

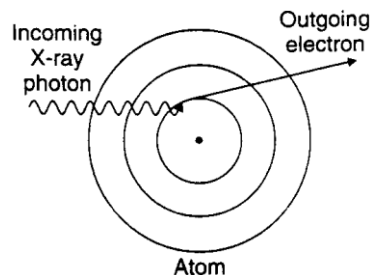

However the likelihood of such a *photoemission* event decreases as the ejected electron's energy increases. This decreasing likelihood makes it difficult for a small atom to absorb an X-ray photon. All of its electrons are relatively weakly bound and the X-ray photon would give the ejected electron a large kinetic energy. Rather than emit a high energy electron, a small atom usually just ignores the passing X-ray.

In contrast, some of the electrons in a large atom are quite tightly bound and require most of the X-ray photon's energy to remove. These electrons would depart with relatively little kinetic energy. Because the photoemission process is most likely when low energy electrons are produced, a large atom is likely to absorb a passing X-ray. Thus the small atoms found in tissue (carbon, hydrogen, oxygen, and nitrogen) rarely absorb medical X-rays, while the large atoms found in bone (calcium) absorb X-rays frequently. That's why bones cast clear shadows onto X-ray film. Tissue shadows are also visible, but they're much less obvious.

While one shadow image of a patient's insides may help to diagnose a broken bone, more subtle problems may not be visible in a single X-ray image. To determine exactly where things are located inside a patient, the radiologist needs to see shadows from several different angles. Better yet, the radiologist can turn to a *computed tomography or CT scanner*. This device automatically forms X-ray shadow images from hundreds of different angles and positions and uses a computer to analyze these images. The computer determines where objects are located inside the patient.

The CT scanner works one "slice" of the patient's body at a time. It sends X-rays through this narrow slice from every possible angle. It determines where the bones and tissues are in that slice. The scanner then shifts the patient's body to work on the next slice.

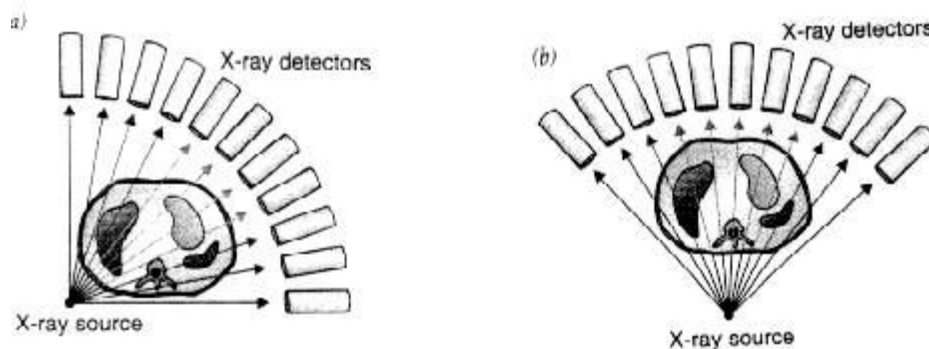

A computerized tomography or CT scan image is formed by analyzing X-ray shadow images taken from many different angles and positions. An X-ray source and an array of electronic X-ray detectors form a ring that rotates around the patient as they patient slowly moves through the ring.

Radiation therapy also uses X-rays, but not the ones used for medical imaging. Even though tissue absorbs fewer imaging photons than bone, most imaging photons are absorbed before they can pass through thick tissue. For example, only about 10% of the imaging photons make it through a patient's leg even when they miss the bone. That percentage is good enough for making an image, but it won't do for radiation therapy because most imaging X-rays would be absorbed long before they reached a deep seated tumor. Instead of killing the tumor, intense exposure to these X-rays would kill tissue near the patient's skin.

To attack malignant tissue deep beneath the skin, radiation therapy uses extremely high energy photons. At photon energies near 1,000,000 eV, the photoelectric effect becomes rare and the photons are much more likely to reach the tumor. Photons still deposit lethal energy in the tissue and tumor, but they do this through a new effect: Compton scattering.

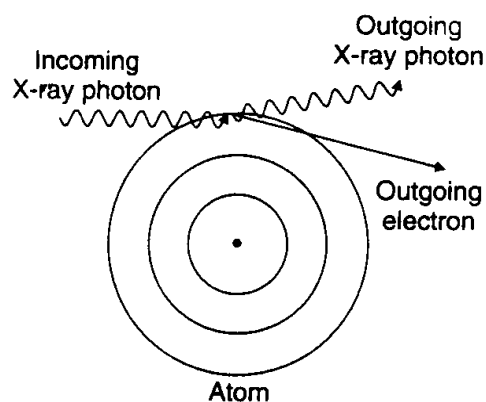

In Compton scattering, an X-ray photon collides with a single electron and the two bounce off one another. The electron is knocked out of the atom.

Compton scattering occurs when an X-ray photon collides with a single electron so that the two particles bounce off one another. The X-ray photon knocks the electron right out of the atom. This process is different from the photoelectric effect because Compton scattering doesn't involve the atom as a whole and the photon is scattered (bounced) rather than absorbed. The physics behind this effect resembles that of two billiard balls colliding, although it's complicated

by the theory of relativity. The fact that it occurs at all is proof that a photon carries both energy and momentum and that these quantities are conserved when a particle of light collides with a particle of matter.

Compton scattering is crucial to radiation therapy. When a patient is exposed to 1,000,000 eV photons, most of the photons pass right through them but a small fraction undergo Compton scattering and leave some of their energy behind. This energy kills tissue and can be used to destroy a tumor. By approaching a tumor from many different angles through the patient's body, the treatment can minimize the injury to healthy tissue around the tumor while giving the tumor itself a fatal dose of radiation.

But Compton scattering isn't the only effect that occurs when high energy photons encounter matter. X-rays with slightly more than 1,022,000 eV can do something remarkable when they pass through an atom—they can cause **electron-positron pair production**. A **positron** is the **antimatter** equivalent of an electron. Our universe is symmetrical in many ways and one of its nearly perfect symmetries is the existence of antimatter. Almost every particle in nature has an antiparticle with the same mass but opposite characteristics. A positron or antielectron has the same mass as an electron, but it's positively charged. There are also antiprotons and anti-neutrons.

Antimatter doesn't occur naturally on earth, but it can be created in high energy collisions. When an energetic photon collides with the electric field of an atom, the photon can become an electron and positron. This event is an example of energy becoming matter. It takes about 511,000 eV of energy to form an electron or a positron, so the photon must have at least 1,022,000 eV to create one of each. Any extra energy goes into kinetic energy in the two particles.

The positron doesn't last long in a patient. It soon collides with an electron and the two annihilate one another—the electron and positron disappear and their mass becomes energy. They turn into photons with a total of at least 1,022,000 eV. So energy became matter briefly and then turned back into energy. This exotic process is present in high energy radiation therapy and becomes quite significant at photon energies above about 10,000,000 eV. Not surprisingly, it also helps to kill tumors.

Gamma Rays

Producing very high energy photons isn't quite as easy as producing those used in X-ray imaging. In principle, a power supply could create a huge voltage difference across an X-ray tube so that very high energy electrons would crash into metal atoms and produce very high energy photons. But million volt power supplies are complicated and dangerous, so other schemes are used instead.

One of the easiest ways to obtain very high energy photons is through the decay of radioactive isotopes. The isotope most commonly used in radiation therapy is cobalt 60 (^{60}Co).

The nucleus of ^{60}Co has too many neutrons and that makes it unstable. It eventually decays, undergoing a series of transformations that produce two high energy photons: one with 1,170,000 eV and one with 1,330,000 eV. These photons penetrate tissue well and are quite effective at killing tumors. So ^{60}Co sources, carefully shrouded in lead containers, are often used in radiation therapy.

The process by which ^{60}Co produces those two high energy photons is complicated but worth describing briefly. It shows that protons, electrons, and neutrons are not immutable and that there are other subatomic particles in our universe. The decay begins when one of the neutrons in a ^{60}Co nucleus abruptly turns into three particles: a proton, an electron, and a *neutrino*. This process is called *beta decay* and can occur because neutrons that are by themselves or in nuclei with too many neutrons are unstable and radioactive. When one of the neutrons in a neutron-rich ^{60}Co nucleus decays, it leaves behind a positively charged proton and the nucleus becomes nickel 60 (^{60}Ni). The negatively charged electron and the neutral neutrino escape from the nucleus and travel outward.

The **neutrino** is a subatomic particle with no charge and little or no mass. Neutrinos aren't found in normal atoms. Though important in nuclear and particle physics, neutrinos are difficult to observe directly because they travel at or near the speed of light and hardly ever collide with anything. Without charge, they don't participate in electromagnetic forces and, unlike the electrically neutral neutron, they don't experience the nuclear force. They experience only gravity and the **weak force**, the last of the four **fundamental forces** known to exist in our universe. (The other three fundamental forces are the gravitational force, the electromagnetic force, and the **strong** force-that's a more complete version of the nuclear force that we discussed in the previous chapter.) Because it's weak and occurs only between particles that are very close together, the weak force rarely makes itself apparent. One of the few occasions where it plays an important role is in beta decay.

With almost no way to push or pull on another particle, a neutrino can easily pass right through the entire earth. Neutrinos can be detected once in a while, but only with the help of enormous detectors. That's why physicists first showed that neutrinos are emitted from decaying neutrons by measuring energy and momentum before and after the decay. The proton and electron produced by the decay don't have the same total energy and momentum as the neutron had before the decay. Something must have carried away the missing energy and momentum and that something is the neutrino.

Once ^{60}Co has turned into ^{60}Ni , the decay isn't quite over. The ^{60}Ni nucleus that forms still has extra energy in it. Nuclei are complicated quantum physical systems just as atoms are and they have excited states, too. The ^{60}Ni nucleus is in an excited state and it must undergo two radiative transitions before it reaches the ground state. These radiative transitions produce very high energy photons or **gamma rays** that are characteristic of the ^{60}Ni nucleus-one with 1,170,000 eV of energy and the other with 1,330,000 eV. These gamma rays are what make ^{60}Co radiation therapy possible.

Particle Accelerators

Electromagnetic radiation isn't the only form of radiation used to treat patients. Energetic particles such as electrons and protons are also used. Like tiny billiard balls, these fast moving particles collide with the atoms inside tumors and knock them apart. As usual, this atomic and molecular damage tends to kill cell and destroy tumors.

However, obtaining extremely energetic subatomic particles isn't easy. High voltage power supplies can be used to accelerate an electron or proton to about 500,000 eV, but that isn't enough. When a charged particle enters tissue, it experiences strong electric forces and is easily deflected from its path. To make sure that it travels straight and true, all the way to a tumor, the particle must have an enormous energy. Giving each charged particle the millions or even billions of eV it needs for radiation therapy takes a particle accelerator. Charge that's sloshing back and forth in a magnetron not only creates microwaves, it also creates huge electric fields that change with time. In a particle accelerator, similar electric fields are used to push charged particles through space until they reach incredible energies.

One important type of particle accelerator is the *linear accelerator*. In this device, charged particles are pushed forward in a straight line by the electric fields in a series of resonant cavities.

Each of these cavities has charge sloshing back and forth rhythmically on its wall, just as charge sloshes back and forth in the cavities of a magnetron. When a small packet of charged particles enters the first cavity through a hole, it's suddenly pushed forward by the strong electric field inside that cavity. The packet accelerates forward and leaves the first resonant cavity with more kinetic energy than it had when it arrived-the electric field in that cavity has done work on the packet.

If the fields in the cavities were constant, the electric field in the second cavity would slow the packet down. In the drawing you can see that the electric field in the second cavity points in the wrong direction. But by the time the packet reaches the second cavity, the charge sloshing in its walls has reversed and so has the electric field. The packet is again pushed forward and it emerges from the second cavity with still more kinetic energy.

Each resonant cavity in this series adds energy to the packet, so that a long string of cavities can give each of the packet's charged particles millions or even billions of eV. This energy comes from magnetron-like microwave generators that are attached to the accelerator. Microwaves from these generators are what cause charge to slosh in the accelerator's microwave cavities. The linear accelerator then only has to inject charged particles into the first cavity, using equipment resembling the insides of a television picture tube, and those charged particles will come flying out of the last cavity with incredible energies.

However there are a few complications to this acceleration technique. Most importantly, the cavities have to be built and operated so that their electric fields reverse at just the right moments to keep the packet accelerating forward. For simplicity of operation, the cavities have the same resonant frequency and all reverse their electric fields simultaneously. Since the

packet spends the same amount of time in each cavity and it travels faster and faster as it goes from one cavity to the next, each cavity must be longer than the previous one.

But as the packet approaches the speed of light, something strange happens. The packet's energy continues to increase as it goes through the cavities, but its speed stops increasing very much. What this means is that the simple relationship between kinetic energy and speed isn't valid for objects moving at almost the speed of light! This breakdown is part of Einstein's **relativity theory**, the rules governing motion at speeds comparable to the speed of light. As a further consequence of relativity, the packet can approach the speed of light but can't actually reach it. Though each charged particle's kinetic energy can become extraordinarily large, its speed is limited by the speed of light.

Because the packet's speed stops increasing significantly after it has gone through the first few cavities of the linear accelerator, the lengths of the remaining cavities can be essentially constant. Only the first few cavities have to be specially designed to account for the packet's increasing speed inside them. The charged particles emerge from the accelerator traveling at almost the speed of light. They pass through a thin metal window that keeps air out of the accelerator and enter the patient's body. They have so much energy that they can penetrate deep into tissue before coming to a stop.

Magnetic Resonance Imaging

While X-rays do an excellent job of imaging bones, they aren't as good for imaging tissue. A better technique for studying tissue is *magnetic resonance imaging* or MRI. This technique locates hydrogen atoms by interacting with their magnetic nuclei. Since hydrogen atoms are common in both water and organic molecules, finding hydrogen atoms is a good way to study biological tissue.

The nucleus of a hydrogen atom is a proton. A proton is effectively a spinning object with charge on its surface and this moving charge gives it a magnetic field. The proton behaves like a tiny bar magnet, with a north pole at one end and a south pole at the other. If you put the proton in a magnetic field, it will tend to align itself with that field. But while protons would align perfectly with the field at absolute zero, thermal energy flips the protons about so that they're only aligned with the field on the average. Some of them are upside down.

However this classical view of the protons as little spinning magnetic balls isn't quite right. They're so small that their behavior is complicated by quantum physics. Because of the wave character of matter, the proton's axis of rotation isn't well defined. Just as the Heisenberg uncertainty principle prevents us from knowing exactly where an object is, we are prevented from knowing exactly what its axis of rotation is. For large objects like a bowling ball, this axis uncertainty is too small to matter. But for a proton, it's significant. The end result here is that the protons adopt one of only two possible alignments with an applied magnetic field: they either partly align with that field or they partly anti-align with it.

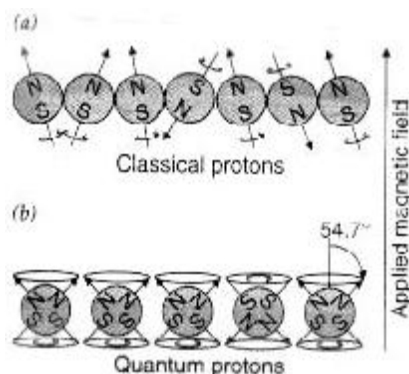

(a) Classical protons are spinning magnetic objects that tend to align roughly with an applied magnetic field. (b) Quantum protons are also magnetic, but their axes of rotation are not so well defined. Their angular momenta can only partly align with the applied field and they appear either spin-up (partly aligned with the field) or, less frequently, spin-down (partly anti-aligned with the field.)

In either case, each axis of rotation is tilted at 54.7° away from alignment or anti-alignment, but you can't tell whether it's tilted toward the left, right, back, or front. The direction of its tilt is hidden by the Heisenberg uncertainty principle. We'll call the protons that partly align with the applied magnetic field "**spin-up**" and the ones that partly anti-align "spin-down." As before, thermal energy keeps these quantum protons from all being spin-up. In fact, even in a strong magnetic field, the spin-up protons only slightly outnumber the spin down protons. To make the following discussion simpler, we'll only consider the extra spin-up protons. The other protons are balanced and don't affect MRI.

When a patient enters the strong magnetic field of an MRI machine, the protons in their body respond to the field and an excess of spin-up protons appears. Because aligning with a magnetic field reduces a bar magnet's potential energy, each of these spin-up protons has less energy than it would have if it were spin-down. While it's possible to convert one of the extra spin-up protons into a spin-down proton, that process takes energy.

An MRI machine uses radio wave photons to flip the extra spin-up protons. When a radio wave photon with just the right amount of energy passes through a spin-up proton, the proton may absorb it in a radiative transition and become a spin-down proton. How much energy the radio wave photon must have depends on how much energy it takes to flip the spin. That energy in turn depends on how strong the magnetic field is around the proton. Since the energy needed to flip the proton's spin increases as the magnetic field gets stronger, the energy of the radio wave photon must also increase with the field. If the protons in the patient's body were all experiencing exactly the same magnetic field, they would all require the same radio wave photon energy to flip. But the protons don't all experience the same field. The MRI machine introduces a slight spatial variation to its magnetic field. Because the magnetic field is different for different protons, only some of them can absorb radio waves of a particular energy. This selective absorption is how the MRI imager locates protons within a patient.

In its simplest form, an MRI machine applies a spatially varying magnetic field to the patient's body. It then sends various radio waves through the patient and looks for those radio waves to be absorbed by protons. Since only a proton that is experiencing the

right magnetic field can absorb a particular radio wave photon, the MRI machine can determine where each proton is by which radio waves it absorbs. By changing the spatial variations in the magnetic field and adjusting the energies of the radio waves, the MRI machine gradually locates the protons in the patient's body. It builds a detailed three-dimensional map of the hydrogen atoms. A computer manages this map and can display cross-sectional images of the patient from any angle or position.

Since its invention in the mid-1970s, MRI has become increasingly sophisticated. A modern MRI machine doesn't fully invert the spin-up protons in the manner we've just discussed. Instead, it flips each proton only half way upside down. The result isn't a "spin-sideways" proton as it might be in a classical universe. Instead it's a quantum proton that's 50% spin-up and 50% spin-down. That means that if you were to measure its current spin, you'd have a 50% chance of finding it spin-up and a 50% chance of finding it spin-down. Before that measurement, the proton is simultaneously in both states.

These two possible states, spin-up and spin-down, correspond to quantum waves which can exhibit interferences. The interferences of a half-flipped proton are extremely sensitive to the magnetic field near the proton and to the radio waves that pass through it. Using these interferences, the MRI machine can not only locate each proton, it can even tell what molecule the proton is in and what the chemical environment of that molecule is like. In this way, an MRI machine can generate detailed images of where water molecules are in the patient, where fat molecules are and even where the patient's blood is flowing.

Nuclear Medicine

The discipline of nuclear medicine began almost a century ago with the discovery of radium. With the discovery and development of artificial radionuclides, following World War II, physicians recognized the potential medical implications of these elements. Since this development, the field of nuclear medicine has become a very important diagnostic discipline. Currently, the use of nuclides enables diagnostic testing of the brain, bones, heart, and most internal organs.

Each atom contains a nucleus about 100,000 times smaller than the atom. The nuclear charge determines the number of electrons in the neutral atom and hence its chemical properties. The nuclear mass determines the mass of the atom. For a given nuclear charge there can be a number of nuclei with different masses or *isotopes*. If an isotope is unstable, it transforms into another nucleus through radioactive decay. Four kinds of radioactivity measurements have proven useful.

Competitive Binding Assays

The first type of radioactive measurement actually does not involve the administration of a radioactive substance to a patient. Rather a sample from the patient (usually blood) is mixed with a radioactive substance in the laboratory, and the resulting chemical compounds are separated and counted. This is the basis of various *competitive binding assays*, such as those for measuring thyroid hormone and the ability of iron binding sites. The most common competitive

binding technique is called *radioimmunoassay*. A wide range of proteins are measured in this manner.

Time Dependent Measurements

In the second kind of measurement, radioactive tracers are administered to the patient in a way that allows the volume of a compartment within the body to be measured. Examples of such compartments are total body water, plasma volume, and exchangeable sodium. Time-dependent measurements can be made, such as red blood cell survival and iron and calcium kinetics. Counting is of the whole body or of blood urine samples drawn at different times after administration of the isotope.

Radionucleotide Imaging

For the third class of measurements, a *gamma camera* generates an image of an organ from radioactive decay of a drug that has been administered and taken up by the organ. These images are often made as a function of time. Nuclear medicine images do not inherent spatial resolution of diagnostic x-ray images; however, they provide functional information: the increase and decrease of activity as the radiopharmaceutical passes through the organ being imaged. Early measurements were made with single detectors such as the scintillation detector (refer to figure #1). Directional sensitivity is provided by a collimator, which can be cylindrical or tapered. Single detectors are still used for *in vitro* measurements and for thyroid uptake studies. Two-dimensional images can be taken with the *scintillation camera* or *gamma camera* (refer to figure #2) The scintillators is 6-12 mm thick and 17 -60 cm in diameter. Modern scintillators are rectangular. The scintillators is viewed by an array of photomultiplier tubes(current cameras use 50-100 tubes), arranged in a hexagonal array. The tube nearest where the photon interacts receives the greatest signal. Signals from each tube are combined to give the total energy signal and also to give x and y positions signals. Figure #3 shows a bone scan of a young patient taken with gamma camera. The ^{99m}Tc -di phosphate is taken up in areas of rapid bone growth at the epiphyses at the end of each bone can be seen. there are also hot spots at the injection site, in one kidney, and in the bladder. Nuclear medicine can show physiologic function. For example, if the isotope is uniformly distributed in the blood, viewing the heart and synchronizing the data accumulation with the electrocardiogram (gating) allows one to measure blood volume in the heart when it is full and contracted, and to calculate the *ejection fraction*, the fraction of blood in the full left ventricle that is pumped out. This is shown in figure #4, which shows pictures and contours of the heart at the end-systole and end-diastole. The imaging agent was ^{99m}Tc -labeled human red blood cells.

Tomography

The fourth class is an extension of these in which tomographic reconstruction of body slices are made. These include *single -proton emission computed tomography and positron emission tomography*. Single-photon emission computed tomography (SPECT): the detector is sensitive to all radioactivity along a line passing through the patient. The counting rate is thus proportional to a projection through the patient, and a cross-sectional slice can be reconstructed from a series of projections, just as was done with x-ray CT. A series of images like those in figure #5, but at more angles, are used to reconstruct a three-dimensional image that can be viewed from any direction, with slices at any desired depth. A SPECT scan is shown in figure #6. There are five

reconstructed slices in planes parallel to the long axis of the heart. The left ventricle is prominent, and the right ventricle can be faintly in the last few slices.

Positron Emission Tomography or P.E.T. is the study and visualization of human physiology by electronic detection of short-lived positron emitting radiopharmaceuticals. It is the only non-invasive technology that can routinely and quantitatively measure metabolic, biochemical and functional activity in living tissue. The P.E.T. scan has emerged as a truly revolutionary method of measuring body function and guiding disease treatment. It assesses changes in the function, circulation and metabolism of body organs. Unlike MRI (Magnetic Resonance Imaging) or CT (Computed Tomography) scans which primarily provide images of organ anatomy, P.E.T. measures chemical changes that occur before visible signs of disease are present on CT and MRI images.

This Nuclear Medicine (NM) imaging technique uses a radioactive tracer or radiopharmaceutical, hundreds of radiation detectors and sophisticated computer technologies to identify the biochemistry of internal organs. Small safe amounts of specific radioactive tracers are administered to patients and research volunteer subjects by injection who are then imaged with a special camera called a P.E.T. Scanner that measures the radioactivity distributed throughout the body and creates three dimensional pictures or images of tissue function

A positron emitter is used as the radionuclide, the positron comes to rest and annihilates an electron, emitting two annihilation photons back to back. These can be detected in coincidence. This simplifies the attenuation correction, because the total attenuation for both photons is the same for all points of emission along each ray through the body. Positrons emitters are short-lived, and for most it is necessary to have an accelerator for producing them in or near the hospital. Some of the lighter positron emitters have the advantage of being natural constituents of molecules in the body (figure #7). A PET scan overlaid on a MRI image is shown in figure #8. Radioactive isotopes are also used for therapy. The patient is given a radiopharmaceutical that is selectively absorbed by a particular organ (e.g., radioactive iodine for certain thyroid diseases), the isotope emits charged particles that lose energy within a short distance, thereby giving a high dose to the target organ.

P.E.T. can be used to visualize rapidly growing tumors, to determine tumor response to radiation and/or chemo therapy, to diagnose recurrence of tumor growth after surgical removal, to decide the best location for biopsying a suspected tumor and to differentiate radiation necrosis from new tumor growth. Positron emission tomography can be used to assess the extent of cardiovascular disease and to aid in the prediction of the success of a coronary bypass operation prior to surgery. P.E.T. has demonstrated that it is a clinically proven, cost effective, and safe method for imaging colon cancer, lung cancer, lymphoma, brain cancer, heart disease and neurological disorders such as Alzheimer's Disease. P.E.T. is also a useful tool in determining whether exploratory surgery, radiation therapy, organ transplantation or other procedures may be necessary

Brachytherapy

Isotopes are also used in self-contained implants for *brachytherapy*. Brachytherapy (*brachy* means short) involves implanting in the tumor sources for which the radiation falls off

rapidly with distance because of attenuation and $1/r^2$. originally the radioactive sources ("seeds") were implanted surgically, resulting in high doses to the operating room personnel. In the *afterloading* technique, developed in the 1960's, hollow catheters were implanted surgically and the sources were inserted after surgery. Remote afterloading, developed in the 1980's, places the sources by remote control, so that only the patient receives a radiation dose. Fractionation of the dose results in better sparing of normal tissue for a given probability of killing the tumor. Afterloading allows the sources to be placed and removed, but it is often difficult for the patient to tolerate the catheters for long periods of time. This has led to the *high-dose-rate* brachytherapy (HDR), in which the dose is given in one or a few fractions over the course of a day or two. Though this is much easier for the patient, tissue sparing is not as great as with a longer treatment. Current practice seeks to compensate for this meticulous treatment planning based on an extended version of the linear-quadratic model, and by making sure that the tumor receives much higher doses than the surrounding normal tissue. Radium was the first brachytherapy source, but it has been replaced by ^{60}Co , ^{192}Ir , and ^{137}Cs . Conventional low-dose-rate brachytherapy is delivered at 0.4-1.0 Gy/Hr. High dose rates are about 1 Gy/min. Internal radiotherapy treats the patient with a radionuclide in a chemical that is selectively taken up by the tumor. The classic example is the administration by mouth of capsules containing ^{131}I for treatment of hyperthyroidism and thyroid cancer. Other nuclides are being used experimentally for breast and neuroendocrine tumors and melanoma. A radionuclide for this purpose should emit primarily nonpenetrating radiation, have a physical half-life long compared to the biological half-life, have a large activity per unit mass, and exhibit a high degree of specificity for the tumor. If the nuclide can be delivered within the cell nucleus, then the high RBE of the Auger electrons can be exploited. One way to achieve high concentrations in the tumor (though not in the nucleus) is to tag monoclonal antibodies with the radionuclide.

Radiation Injury

Most damage that is done in living tissues is done by the process of ionization and in some cases by excitation. The mechanism of action of injury occurs by what is called the *Adirect@* and *Aindirect@* methods.

Direct Action (Target Theory)

In this situation there is a direct hit on the target molecules within the cell. DNA linkage bonds are affected the most and the cell is damaged.

Indirect Action

In this case, radiant energy loads to radiolysis of the cell water, creating the *Ahot@* radicals H_2O^+ and H_2O^- . These dissociate to H. and OH. These free radicals interact with membranes, nucleic acids and other enzymes causing damage to the cells and the cells function.

Indirect	Direct (Target)
Gamma rays X-rays	Charged particles

The actions mentioned above takes seconds to occur, but the affect may take minutes or

even decades to be detected.

Quantization of Radiation

1. Exposure

This measurement seeks to define actual exposure to radiation. Roentgen (R) measures exposure to x-rays and gamma rays. One (1) R is the quantity of radiation that induces an emission equal to 1 electrostatic unit of charge in 1 cc of air.

2. Absorption

Another way to look at how radiation affects living tissue is to see how much is absorbed by living tissue. Absorption is measured using the *radiation absorbed dose* or *rad*. One (1) rad (r) is the dose resulting in the absorption of 100 ergs of energy per gram of target tissue for any type of radiation. The SI unit of absorption is the Gray (g). One gray = 100 rads.

BIOLOGICAL EFFECTS

Exposure and absorption do not describe the actual effects on living tissue. So another set of measurements is needed. The relative effects of different types of radiation given at different doses are compared in terms of their linear energy transfer (LET), relative biological effectiveness (RBE) or the roentgen equivalent man (REM).

LET: This is the energy loss per unit of travel. In other words what is the likelihood of radiation having an effect within a target area. X and gamma rays have low LET values. They penetrate deeply but generate few interactions.

RBE: This relates to the amount of cellular damage caused by a specific amount of energy. Also the number of RADs of x or gamma radiation that produces the same biological effect as 1 rad of the radiation being used.

REM: This is the dose equal to rad x RBE

DOSE IN RADS	PROBABLE EFFECT
10 to 50	No obvious effect except possible minor blood changes
50 to 100	Vomiting and nausea for about one day in 5% of exposed personal. No serious reaction. Transient blood problems.
100 to 200	Vomiting and nausea for one day, followed by other symptoms of radiation sickness in 20% to 50% of people. No deaths anticipated.
200 to 350	Vomiting and nausea in nearly all people on first day, followed by other symptoms of radiation sickness, loss of appetite, diarrhea, hemorrhage. About 20% will die within 6 weeks. 75% reduction in circulating blood elements.
350 to 550	Vomiting and nausea in most people on the first day, then other radiation sickness symptoms. About 50% will die within one month. Survivors will be sick for about 6 months.
550 to 750	Vomiting and nausea in all people within 4 hours, followed by severe symptoms of radiation sickness. Up to 100% will die.
1000	Vomiting and nausea in all people with 1 to 2 hours All dies within days.
5000	Immediate incapacitation. All people will die within one week

Brain: Mostly resistant

Skin: Erythema and edema early on. Atrophy and skin cancer up to years later.

Lungs: Edema adult respiratory distress syndrome

GI tract: Mucosal injury, ulceration

Gonads: Destruction of spermatogonia, spermatids and sperm in testes and destruction of germ cells in the ovaries.

Blood and bone marrow: Thrombocytopenia and anemia and granulocytopenia

Some Useful Definitions

Collimator	Radiographic device used to limit the scatter and extent of the x-ray beam
Scintillation	The emissions that come from radioactive substances
Gating	Medical image information consistently collected during a specific phase of the cardiac cycle
Positron	A particle having the same mass as a negative electron but possessing a positive charge
Annihilate	To reduce to nothing; wipe out of existence.
Radionuclide	Atom that disintegrates by emission of electromagnetic radiation.
Gy	In the SI system, the unit of absorbed radiation energy
RBE	Relative biological effectiveness
Auger electrons	Electrons emitted as alternatives to characteristic x-rays.
Monoclonal	Arising from a single cell.

Ultrasound

Ultrasound has been in use in medicine for many years. In the past, its primary applications were to monitor a fetal heart rate during labor and delivery and for evaluating blood flow in the carotid artery. However, in the last two decades ultrasound applications have extended into virtually all aspects of medical specialties including cardiology, neurology, radiology, obstetrics, pediatrics, and surgery.

The physical principle which allows us to apply ultrasound is the "Doppler Principle." This theory was first described in 1842 by the Austrian physicist Christian Doppler at the Royal Bohemian Society of Science in Prague. This principle is a "wave theory" which can be applied to measure velocity of moving objects.

Ultrasound waves are created, as well as detected, by an ultrasonic transducer. The main element in such a transducer is a small *piezo-electric crystal*. If an electrical signal is applied to this crystal, it will either expand or contract. Thus, if a *pulsed* or *oscillating* electric signal is

applied, the crystal can vibrate at a high frequency. When it is compressed or expanded, it creates an electric signal. This allows us to detect ultrasound as well as produce it. Frequencies above 20 kHz are considered ultrasound (maximum audible range for humans is 20-20,000 Hz). In medical applications frequencies may range from 1-20 MHz. Transducers used in modern medicine are designed to emit waves which do not spread out as they travel. As a result, the intensities of the waves stay relatively constant except for natural *attenuation* by the medium(s) through which it travels, as discussed below.

Ultrasound is a form of sound and thus travels with the velocity of sound; approximately 340 m/s in air, 1550 m/s in water as well as most soft tissues in the body, 4000 m/s in bone, and 5000 m/s in most metals. As ultrasound waves travel through substance, they tend to lose some of their energy to the material (often in the form of heat, etc.). This process is called *attenuation*. This attenuation, or absorption, depends on the frequency (or frequency squared) of the ultrasound and on the distance through which the waves must travel. Some typical attenuation factor (a) values are listed below:

<u>Material</u>	<u>(a) dB/cm</u>	<u>Dependence</u>
Air	Negligible	N/A
Blood	0.2	f
Bone	20	f ²
Lungs	40	f
Muscle (X-sect.)	3.3	f
Soft Tissue	0.8	f
Water	0.0022	f ²

Change in attenuation, B, is approximated as: $[-adf^2]$, where d represents distance that ultrasound travels. So, the lower the frequency, the lower the attenuation will be.

Another factor that affects the use of ultrasound is *impedence*. Roughly speaking, impedance represents how much a medium tries to resist the entry or exit of a wave. This can be calculated by the following equation: $Z=pv$; where p is the density of the medium and v is the speed of sound in the medium. The importance of this lies in the fact that the fraction of ultrasound intensity *reflected* at the boundary between two media is given by:

$$R=(Z_1-Z_2/Z_1+Z_2)^2$$

Some values of impedance:

<u>Material</u>	<u>Z (kg/m².s)</u>
Air	400
Blood	2x10 ⁶
Bone	6.1x10 ⁶
Fat	1.38x10 ⁶
Lung	-500
Soft Tissue	1.36x10 ⁶
Water	1.5x10 ⁶

The fraction of ultrasound intensity transmitted through the boundary between two media is given by: $T=I-R$. Thus, when T is low and R is high, most of the ultrasound will be reflected.

This is the case when two media have very different impedances. On the other hand, if the impedances are similar for the two materials, there will be little reflection-most of the intensity will be transmitted.

As mentioned earlier, there are various medical applications of ultrasound. Perhaps the most fascinating and popular use is to develop images inside the human body. To overcome the high impedance between skin and air, a gel is used. This gel essentially has the same characteristics as water, so the impedance is similar to that of human tissue. Frequencies between 1-10 MHz are normally used for medical imaging. This range allows for resolution of objects on the order of 1mm or less. When a pulse is sent into the body, a little intensity is reflected at each tissue interface. Since we know the velocity of ultrasound, we can calculate how far the tissue interface lies beneath the surface of the body by measuring the time between pulse and echo. In order to produce full images inside the body, a transducer with multiple piezoelectric crystals is needed. These crystals are pulsed so that a computer can determine which echos originated with which crystal and an image can be formed which corresponds to a cross-section of the body. Other uses of ultrasound include, in brief, the following:

1) Ultrasonic Blood Flow Meters. This takes advantage of the Doppler Effect. An ultrasound wave is projected into a vessel such that the ultrasound is traveling nearly parallel to the blood flow. Due to the blood movement, the reflected waves have a different frequency than the incident waves. By measuring the change in frequency, the blood velocity can be determined.

2) Ultrasonic Cleaning. Ultrasound with high intensity can be used to clean thin layers of unwanted dirt and grease from objects. In a process known as *cavitation*, the high frequency waves cause small, momentary gaps to form between the fluid and object. The gaps act like small, powerful vacuums, pulling off the dirt and grease molecules.

Problems

Chapter 2: ENERGY, HEAT, WORK, AND POWER OF THE HUMAN BODY

1. A 75.0 kg weight-watcher wishes to climb a mountain to work off the equivalent of a large piece of chocolate cake rated at 500 food Calories (kilocalories). How high must the person climb?
2. A hiker weighing 575 N carries a 175 N pack up Mt. Whitney (elevation 4420 m), increasing her elevation by 3000 m.
 - (a) Find the minimum internal work done by the hiker's muscles.
 - (b) If she is capable of producing up to 746 W (1.0 hp) for an extended time, what is the minimum time for her to ascend?
3. As part of your exercise routine you climb a 10.0 m rope. How many food Calories (kilocalories) do you expend in a single climb up the rope?
4. How much heat is carried away from the body of a sweating person in 1 hour by the evaporation of 0.500 liter of water from the skin?
5. A student is trying to decide what to wear. The air in his bedroom is at 20.0EC. If the skin temperature of the unclothed student is 37.0EC, how much heat is lost from his body in 10.0 min? Assume that the emissivity of skin is 0.900 and that the surface area of the student is 1.50 m².

Chapter 3: MUSCLE AND FORCES

1. A steel band exerts a horizontal force of 80.0 N on a tooth at a point **B** in the figure. What is the torque on the root of the tooth about point **A**?

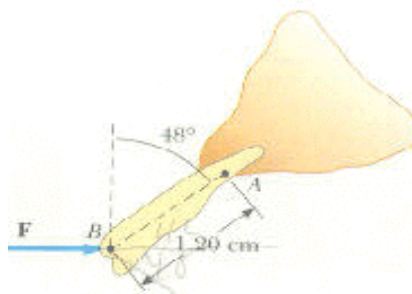

2. The arm in the figure weighs 41.5 N . The weight of the arm acts through point **A**. Determine the magnitudes of the tension force \mathbf{F}_t in the deltoid muscle and the force \mathbf{F}_s of the shoulder on the humerus to hold the arm in the position shown.

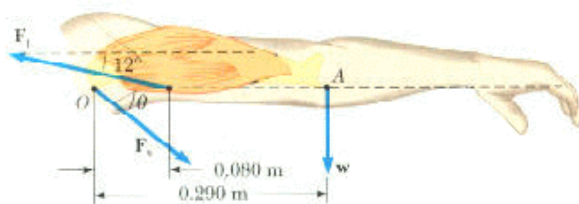

3. The chewing muscle, the masseter, is one of the strongest muscles in the human body. It is attached to the mandible. The jawbone is pivoted about a socket just in front of the auditory canal. The forces acting on the jawbone are equivalent to those acting on the curved bar below. **C** is the force exerted against the jawbone by the food being chewed, **T** is the tension in the masseter, and **R** is the force exerted on the mandible by the socket. Find **T** and **R** if you bite down on a piece of steak with a force of 50.0 N .

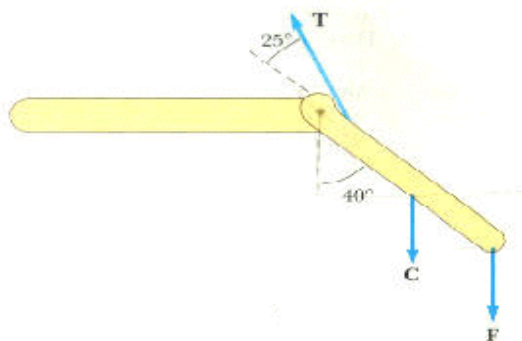

4. The large quadriceps muscle in the upper leg terminates at its lower end in a tendon attached to the upper end of the tibia. The forces on the lower leg when the leg is extended are modeled in the figure, where \mathbf{T} is the tension in the tendon, \mathbf{C} is the weight of the lower leg, and \mathbf{F} is the weight of the foot. Find \mathbf{T} when the tendon is at an angle of 25.0° with the tibia, assuming that $\mathbf{C} = 30.0 \text{ N}$, $\mathbf{F} = 12.5 \text{ N}$, and the leg is extended at an angle of 40.0° with the vertical ($\theta = 40.0^\circ$). Assume that the center of gravity of the lower leg is at its center, and that the tendon attaches to the lower leg at a point one fifth of the way down the leg.

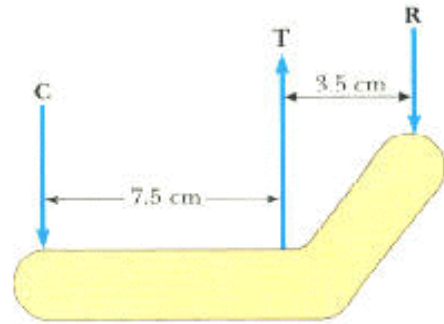

Chapter 4: PHYSICS OF THE SKELETON

- 1 The total cross-sectional area of the load-bearing calcified portions of the two forearm bones is approximately 2.5 cm^2 . During a car crash, the forearm is slammed against the dashboard. The arm comes to rest from an initial speed of 80 km/h in 5.0 ms . If the arm has an effective mass of 3.0 kg and bone material can normally withstand a maximum compressional stress of $6 \times 10^7 \text{ Pa}$, is the arm likely to withstand the crash?
- 2 Bone has a Young's modulus of about $14.5 \times 10^9 \text{ Pa}$. Under compression, it can withstand a stress of about 160×10^6 before breaking. Estimate the length of your femur, and calculate the amount of compression this bone can withstand before breaking.
- 3 (a) Compute the torque required to break a tibia that has a radius of 1.00 cm at its thinnest point, if the maximum stress at fracture is $2.00 \times 10^8 \text{ N/m}^2$.
(b) Suppose a football player is being tackled by one opponent who holds his ankle in a fixed position while another opponent applies a horizontal force to his knee, 0.500 m above the ankle. What is the maximum value of the force that can be applied before the bone will break?
- 4 A weight lifter holds $1.0 \times 10^3 \text{ N}$ (230 lb) directly overhead. In the midsection of his body this weight is supported by his spine. Spinal vertebrae are separated by easily compressible disks, each disk having an average cross-sectional area of $1.0 \times 10^{-3} \text{ m}^2$. Young's modulus for a disk is $7.0 \times 10^6 \text{ N/m}^2$. The total thickness of all the intervertebral disks is 15 cm . Compute the weight lifter's decrease in height resulting from the compression of the disks. For simplicity, ignore the effect of the upper body's weight on the spine.

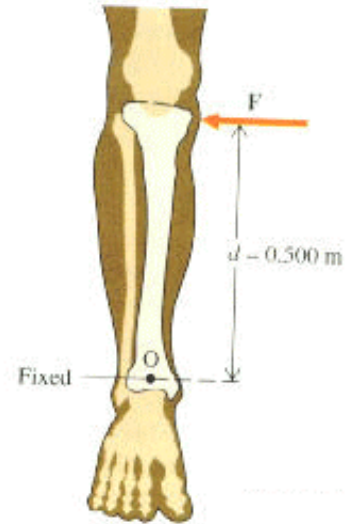

Chapter 5: PRESSURE IN THE BODY

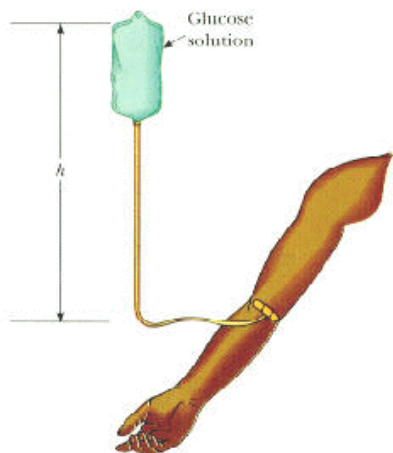

1 A collapsible plastic bag contains a glucose solution. If the average gauge pressure in the artery is 1.33×10^4 Pa, what must be the minimum height, h , of the bag in order to infuse glucose.

2. A person rides up a ski lift, but his ears fail to Δ pop@ that is, the pressure of the inner ear does not equalize with the outside atmosphere. The radius of each eardrum is 0.40 cm. On the way up, the pressure of the atmosphere drops from 1.010×10^5 Pa to 0.998×10^5 Pa.

- What is the gauge pressure of the inner ear at the top of the mountain?
- What is the net force on each eardrum?

- When a major artery is cut, the blood squirts out because of the high arterial pressure. Compute the vertical rise of a stream of blood from a small cut in a major artery in the leg, 1.00 m below the heart. Use average arterial pressure (100 torr).
- Suppose that an inexperienced person measured blood pressure with the arm raised so that the cuff was 20.0 cm above the level of the heart. If the blood pressure is actually normal, what readings would be obtained from this measurement?
- A woman hangs by her feet from Δ gravity boots@ that support her weight from above. The average blood pressure in her aorta is 100 torr. What is the average blood pressure in a major artery in her ankle, at a point 1.10 m above the aorta?
- A blood vessel of inner radius 1.00 mm carries blood at an average speed of 3.00 cm/s. Find the pressure drop along a 1.00 cm length of the blood vessel.
- When a person inhales, air moves down the bronchus at 15 cm/s. The average flow speed of air doubles through a constriction in the bronchus. Assuming incompressible flow,

determine the pressure drop in the constriction.

Ch. 7: PHYSICS OF THE LUNG AND BREATHING

1. When a person inhales, air moves down the bronchus (windpipe) at 15 cm/s. The average flow speed of the air doubles through a constriction in the bronchus. Assuming incompressible flow, determine the pressure drop in the constriction.
2. In the lungs, the respiratory membrane separates tiny sacs of air (absolute pressure = 1.00×10^5 Pa) from the blood in the capillaries. The average radius of the alveoli is 0.125 mm, and the air inside contains 14% oxygen. Assuming that the air behaves as an ideal gas at body temperature (310 K), find the number of oxygen molecules in one alveoli.
3. In the lungs, alveolar oxygen diffuses into the blood through the walls of the alveoli. The walls are very thin, so the oxygen diffuses over a distance L that is quite small. Because there are so many alveoli, the effective area A across which diffusion occurs is very large. Use this information, together with Fick's law of diffusion, to explain why the mass of oxygen per second that diffuses into the blood is large.

Ch. 8: PHYSICS OF THE CARDIOVASCULATURE SYSTEM

1. (a) Calculate the flow rate (in grams per second) of blood ($\rho = 1.0 \text{ g/cm}^3$) in an aorta with a cross-sectional area of 2.0 cm^2 if the flow speed is 40 cm/s .
(b) Assume that the aorta branches to form a large number of capillaries with a combined cross-sectional area of $3.0 \times 10^3 \text{ cm}^2$. What is the flow speed in the capillaries?
2. In the condition known as atherosclerosis, a deposit or arteroma forms on the arterial wall and reduces the opening through which blood can flow. In the carotid artery in the neck, blood flows three times faster through a partially blocked region than it does through an unobstructed region. Determine the ratio of the effective radii of the artery at two places.
3. A vertical force of $1.61 \times 10^{-2} \text{ N}$ is required to lift a wire ring of radius 1.75 cm from the surface of a container of blood plasma. Calculate the surface tension of blood plasma from this information.
4. The pulmonary artery, which connects the heart to the lungs, has an inner radius of 2.6 mm and is 8.4 cm long. If the pressure drop between the heart and lungs is 400 Pa , what is the average speed of blood in the pulmonary artery?
5. A sample of blood is placed in a centrifuge of radius 15.0 cm . The mass of a red corpuscle is $3.0 \times 10^{-16} \text{ kg}$, and the magnitude of the centripetal force required to make it settle out of the plasma is $4.0 \times 10^{-11} \text{ N}$. At how many revolutions per second should the centrifuge operate?
6. An aneurysm is an abnormal enlargement of a blood vessel such as the aorta. Suppose that, because of an aneurysm, the cross-sectional area A_1 of the aorta increases to a value $A_2 = 1.7A_1$. The speed of the blood ($\rho = 1060 \text{ kg/m}^3$) through a normal portion of the aorta is $v_1 = 0.40 \text{ m/s}$. Assuming that the aorta is horizontal (person lying down), determine the amount by which the pressure P_2 in the enlarged region exceeds the pressure P_1 in the normal region.
7. Suppose that blood flows through the aorta with a speed of 0.35 m/s . The cross-sectional area of the aorta is $2.0 \times 10^{-4} \text{ m}^2$. (a) Find the volume flow rate of the blood. (b) the aorta branches into tens of thousands of capillaries whose total cross-sectional area is about 0.28 m^2 . What is the average blood speed through them?

Ch. 9: ELECTRICAL SIGNALS WITHIN THE BODY

1. Suppose that the extracellular fluid of a cell has a potassium ion concentration of 4.50×10^{-3} mol/L and the intracellular fluid has a potassium ion concentration of 1.38×10^{-1} mol/L. Calculate the potential difference across the cell membrane. Neglect the diffusion of any other ions across the membrane and assume a temperature of 310 K.

2. A model of a red blood cell portrays the cell as a spherical capacitor- a positively charged liquid sphere of surface area A , separated by a membrane of thickness t from the surrounding, negatively charged fluid. Tiny electrodes introduced into the interior of the cell show a potential difference of 100 mV across the membrane. The membrane's thickness is estimated to be 100 nm and its dielectric constant to be 5.00. (a) if an average red blood cell has a mass of 1.00×10^{-12} kg, estimate the volume of the cell and thus find its surface area. The density of blood is 1100 kg/m^3 . (b) Estimate the capacitance of the cell. (c) Calculate the charge on the surface of the membrane. How many electronic charges does this represent?

Chapter 11: PHYSICS OF THE EAR AND HEARING

1. The area of a typical eardrum is about $5.0 \times 10^{-5} \text{ m}^2$. Calculate the sound power (the energy per second) incident on an eardrum at (a) the threshold of hearing and (b) the threshold of pain.

Threshold of hearing: $I = 10^{-12} \text{ W/m}^2$

Threshold of pain: $I = 1 \text{ W/m}^2$

2 The human ear canal is about 2.8 cm long. If it is regarded as a tube open at one end and closed at the eardrum, what is the fundamental frequency around which we would expect hearing to be best? Speed of sound, use: $v = 340 \text{ m/s}$

Ch. 12: PHYSICS OF EYES AND VISION

1. The near point of an eye is 100 cm. (a) What focal length should the lens have so that the eye can see an object 25.0 cm in front of it? (b) What is the power of the lens?
2. A certain young girl can adjust the power of her eye=s lens-cornea combination between limits of +57 diopters and +65 diopters. With the lens relaxed, she can see a distant star clearly. (a) How far is this girl=s near point from her eye? (b) How far is her retina from her eye lens?
3. A certain child=s near point is 10.0 cm; her far point (with the eye lens relaxed) is 125 cm. Each eye lens is 2.00 cm from the retina. (a) Between what limits, measured in diopters, does the power of this lens-cornea combination vary? (b) Calculate the power of the eyeglass lens this child should use for relaxed distance vision. Is the lens converging or diverging?
4. An elderly sailor is shipwrecked on a desert island but manages to save his eyeglasses. The lens for one eye has a power of +1.20 diopters, and the other lens has a power of +9.00 diopters. (a) What is the magnifying power of the telescope he can construct with the lenses? (b) How far apart are the lenses when the telescope is adjusted for minimum eyestrain?
5. (a) Calculate the limiting angle of resolution for the eye, assuming a pupil diameter of 2.00 mm, a wavelength of 500 nm in air, and an index of refraction for the eye of 1.33. (b) What is the maximum distance from the eye at which two points separated by 1.00 cm could be resolved?
6. The near point of an eye is 75 cm. (a) What lens power should be prescribed to enable the eye to see an object clearly at 25 cm? (b) If the user can see an object clearly at 26 cm but not 25 cm, by how many diopters did the lens grinder miss the prescription?
7. If a typical eyeball is 2.0 cm long and has a pupil opening that can range from about 2.0 mm to 6.0 mm, what is (a) the focal length of the eye when it is focused on objects 1.0 m away, (b) the smallest f -number of the eye when it is focused on objects 1.0 m away, and (c) the largest f -number of the eye when it is focused on objects 1.0 m away?

1. Positron Emission Tomography

Certain radio active isotopes decay by positron emission, for example $^{15}_8\text{O}$. Such isotopes can be injected into the body, where they collect at specific sites. The positron (^0_1e) emitted during the decay of the isotope encounters an electron ($^0_{-1}\text{e}$) in the body tissue almost at once. The resulting mutual annihilation produces two γ -ray photons ($^0_1\text{e} + ^0_{-1}\text{e} \rightarrow 2\gamma$), which are detected by devices mounted on a ring around the patient. The two photons strike oppositely positioned detectors on the ring and reveal the line along which the annihilation occurred. This is then used to create a computer generated image.

- For each photon, determine (a) its energy (in MeV), (b) its wavelength, and (c) the magnitude of its momentum (the kinetic energies of the particles are negligible).
- 2.** A 2.0-kg tumor is being irradiated by a radioactive source. The tumor receives an absorbed dose of 12 Gy in a time of 850 s. Each disintegration of the radioactive source produces a particle that enters the tumor and delivers an energy of 0.40 MeV. What is the activity $\Delta N/\Delta t$ of the radioactive source?
- 3.** A film badge worn by a radiologist indicates that she has received an absorbed dose of 2.5×10^{-5} Gy. The mass of the radiologist is 65 kg. How much energy has she absorbed?